

Tufline[®] Lined Plug Valves

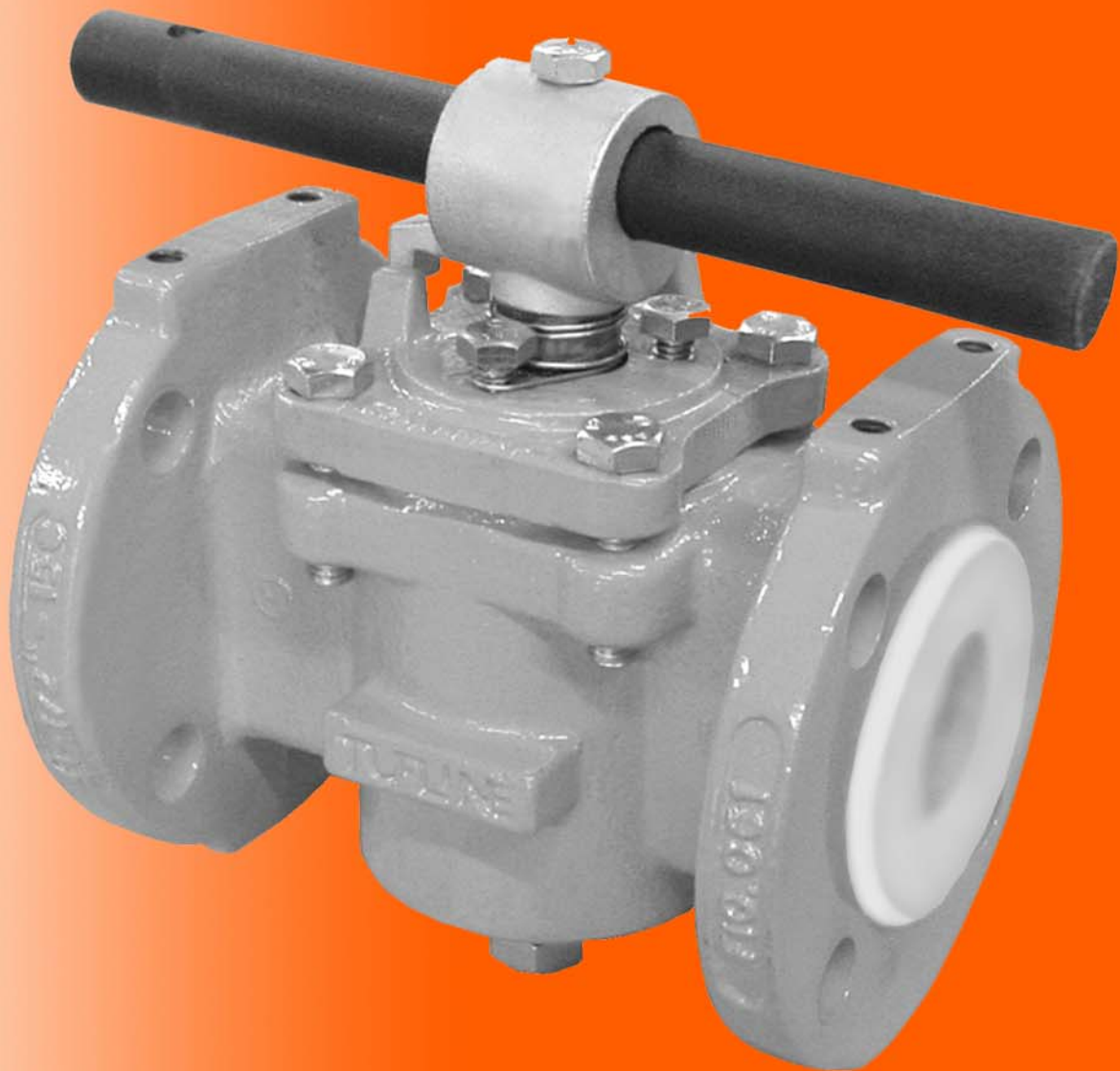

Contents	Page
Design features	2
Lining materials	4
Dimensions	6
2-way operating torques	8
2-way Cv factors	8
Pressure-temperature ratings ..	8
Methods of operation	8
Actuator mounting dimensions ..	9
3-way operating torques, Cv factors, and port arrangements	10
Quality assurance, vacuum, oxygen, chlorine services, custom valves, actuators, locking devices ..	10
Selection guide, how to order ..	11
Worldwide locations	12

© Copyright Xomox Corporation 1998, 2007. All rights reserved. Tufline®, Xomox® and Matryx® are registered trademarks of Xomox Corporation. Teflon® is a registered trademark of DuPont™ used under license. Xomox XRP™ is a trademark of Xomox Corporation.



Tufline® 2-way and 3-way fully lined plug valves feature an encapsulated plug rotating in a fully lined body.

Superior PFA linings economically handle the most corrosive fluids.

Locked in lining.

Tufline lined valve bodies and plugs incorporate dovetail recesses. With these recesses and machined grooves, linings are locked to the body and plug.

The locked in lining resists shrinkage, collapse, and blow-out. Higher pressures and vacuums are easily handled.

(See page 4 for comparisons of various lining methods.)

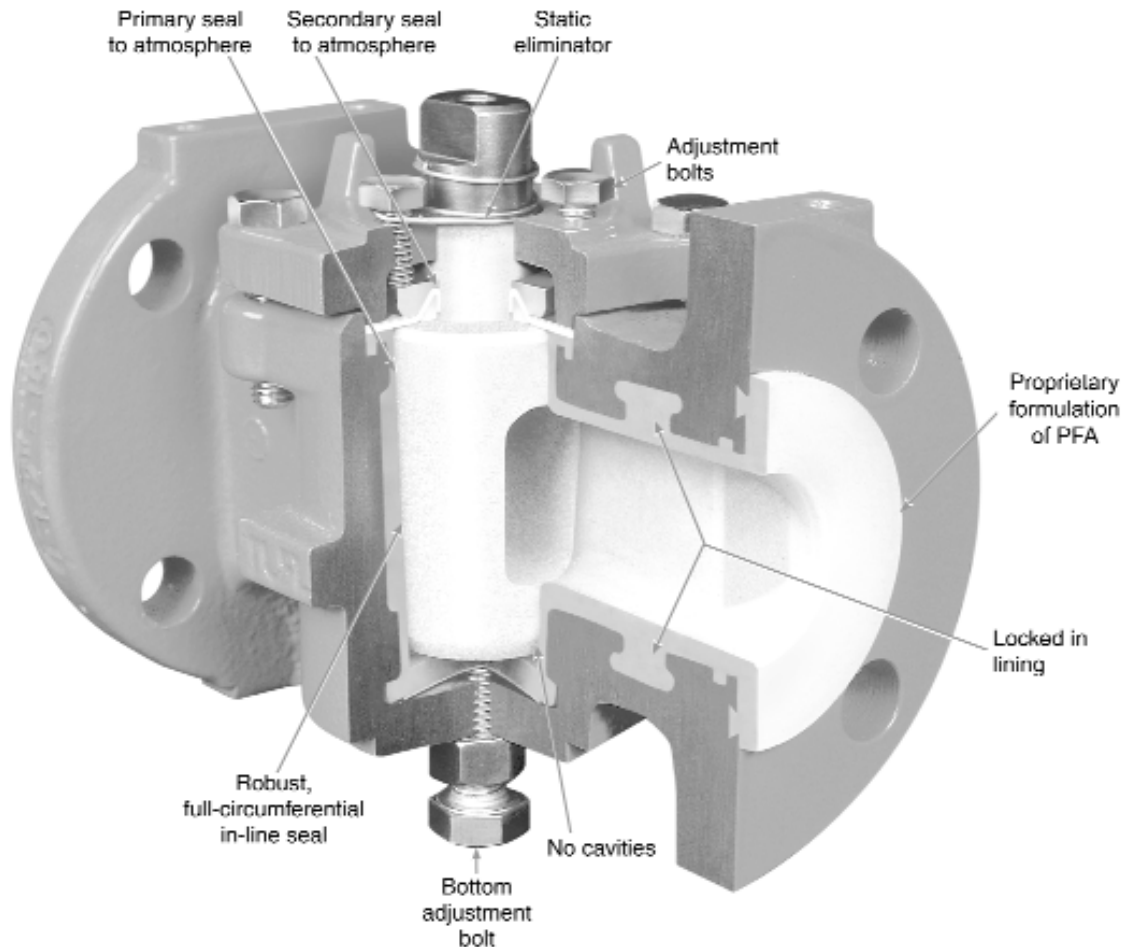

Primary sealing.

A continuous primary seal results from the interaction of the tapered plug and the tapered body bore.

Cast-in ribs behind the body lining concentrate compression of the lining between the ribs and the plug. This assures a full circumferential in-line seal. There is also a full circumferential seal around the plug, both above and below the flow passage.

There are no cavities where flow media can accumulate or contaminate.

Easily adjusted seal.

The three adjusting bolts in the cover and the bottom adjustment bolt work together to assure a maximum sealing capability and an extended service life.

More information.

Application & Corrosion Data.

Xomox publishes a comprehensive, 12-page brochure which lists nearly 500 chemicals and the relative appropriateness of various valve materials.

This and much more in-depth information about the full line of Xomox valves and accessories is available on-line at

www.xomox.com.

Xomox Regional Offices, and Authorized Distributors are also listed on the web site.

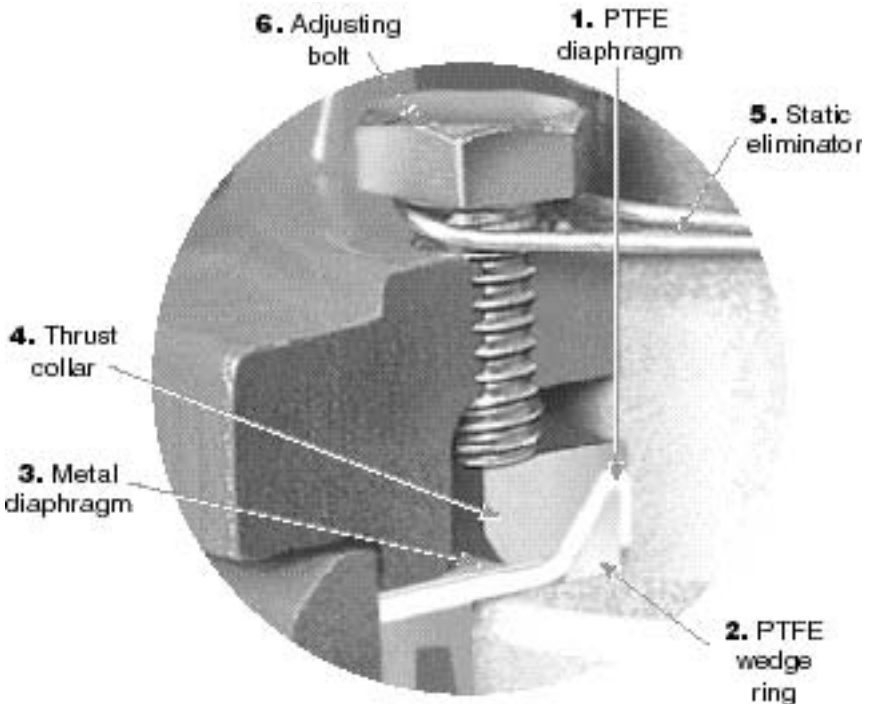

Secondary seal.

In addition to the primary seals, there is a secondary seal system consisting of interacting components.

The secondary stem seals, located above the plug, protect against external leakage up to 400°F.

1. The PTFE diaphragm is shaped into an inverted V at its inner circumference. It seals at the cover joint and against the plug shank.

2. To help assure positive sealing and easy adjustment, the PTFE wedge ring fits into the V-formed inner circumference of the PTFE diaphragm. Sealing force is transmitted from the thrust collar (4) through the wedge ring.

3. A metal diaphragm is above the PTFE diaphragm and wedge ring. This metal diaphragm provides metal-to-metal contact at the cover joint. This prevents cold-flow of the PTFE diaphragm.

This configuration provides two independent compression seals between the body and the cover. One seal is plastic; the second is metal.

4. On top of the metal diaphragm is a floating thrust collar which acts to assure uniform pressure on all sealing surfaces.

5. Above the cover, on the plug shank of wrench operated valves, is a static eliminator which provides a positive electrical ground between the body and the plug.

6. Three adjusting bolts in the cover impart downward force through the thrust collar (4), to the wedge ring (2), then to the inner leg of the inverted "V" of the PTFE diaphragm (1).

This, together with the opposing force of the plug, provides a pressure assisted seal which is not adversely affected by plug movement. The adjusting bolts also facilitate quick and easy adjustment of in-line sealing.



**2-way, ANSI Class 150,
fully lined plug valve.
Figure No. 061**

1/2 - 12 inch . . . PFA lined.



**2-way, ANSI Class 300,
fully lined plug valve.
Figure No. 0361**

1 - 6 inch . . . PFA lined.



**3-way, ANSI Class 150,
fully lined plug valve.
Figure No. 031**

1 - 4 inch . . . PFA lined.

Most international flange ratings and drilling are available. Contact factory for more information.

Lining materials and methods.

For corrosive applications, both the choice of lining materials and the method of lining are critical considerations.

PFA lining material is melt-processible. Melt-processibility means that this lining material can be locked to the valve body and plug using cast-in dovetail recesses and machined grooves. (PTFE cannot be locked in.)

PFA's temperature ranges is:
PFA is rated to 400 F.

PFA properties include:

- Chemical inertness
- Excellent permeation resistance
- Negligible moisture absorption
- Stress-cracking resistance
- Low coefficient of friction
- Insolubility in solvents
- Low adhesion properties
- Wide service temperature range
- Toughness
- Flexibility

PFA.

PFA is a class of perfluoropolymers that offers the processing ease of conventional thermoplastics but substantially extends its temperature limits. It is a copolymer that combines the carbon-fluorine backbone of fluorocarbons with a perfluoroalkoxy side chain.

PFA is a true thermoplastic and is melt processible, allowing it to be molded to complex shapes.

PFA resin has a branched polymer chain that provides good mechanical properties at melt viscosities much lower than those of PTFE.

However, the unique branch in PFA is longer and more flexible, leading to improvements in high temperature properties, higher melting point, and greater thermal stability. The strength and stiffness of PFA at high operating temperatures are equivalent to or better than those of PTFE, and creep resistance is better than PTFE over a wide temperature range.

In addition to properties in common with PFA has been found to be better in handling some monomers, such as butadiene.

It can be molded and machined to close tolerances for excellent seal and wear resistance between parts.

Compare lining methods.

There are two ways to line valves, molding and forming. The lining method depends upon the lining material used.

PFA.

PFA is melt processible. This means that it can be precisely molded to the valve body and locked into place. Locking is accomplished by molding the lining into dovetail recesses or grooves in the valve body. The locking resists liner collapse.

PTFE.

Because of the limitations involved in conforming PTFE to the shape of the valve passage way, it is more vulnerable to failure.

PTFE is not melt processible. It does not become molten at elevated temperatures. Consequently, it cannot be molded in the same way as PFA. As a valve liner, PTFE is limited to the blow-molding method.

With blow-molding, PTFE cannot be "locked" into the valve body. PTFE is susceptible to separation from the valve body in several ways including blow-out, collapse, and creep.

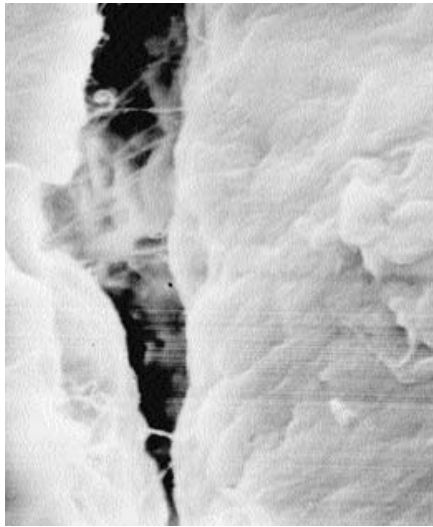

PTFE at 2,000X



PFA at 10,000X

Compare porosity.

In PTFE, microscopic pores are present due to imperfect particle fusion during processing.

To compensate for PTFE's greater porosity, thicker linings must be applied. Because of PTFE's greater lining thickness, the lining is less flexible and sealing is less reliable.

More flexible, less porous PFA linings assure better sealing.

Picture proof.

The scanning electron microscope fractographs above illustrate the difference in valve lining materials.

PTFE.

In the photo at the left above, PTFE is magnified just 2,000 times.

The PTFE microscopic fissures are large enough to easily allow a wide variety of media to migrate through to the base metal.

PFA

In the photo at the right above, PFA is enlarged to 10,000X. This is five times greater magnification than the PTFE, yet no fissures are visible.

Tufline PFA is a proprietary formulation. Minute amounts of PTFE are added to enhance lubricity and assure free turning.

This small amount of PTFE has little or no affect on the superior lining characteristics of PFA.

Physical properties

Property	PFA Perfluoroalkoxy	
	ASTM method	Value
Melting point	-	575 - 590°F
Tensile strength, 73°F	D638	3,800 psi
Elongation, 73°F	D638	300%
Flexural modulus, 73°F	D790	100,000 psi
Impact strength, 73°F	D256	No break
Coefficient of linear thermal expansion per °F	D696	6.7×10^{-5} (70° to 212°F)
Flammability	D635	Nonflammable
Weather and chemical resistance	-	Excellent

Class 150, 2-way, Fig. No. **061**

Class 300, 2-way, Fig. No. **0361**

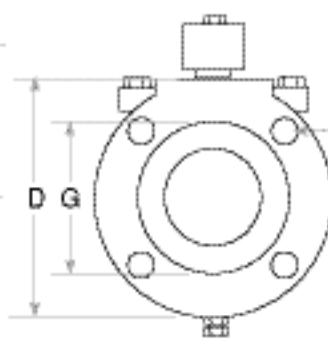
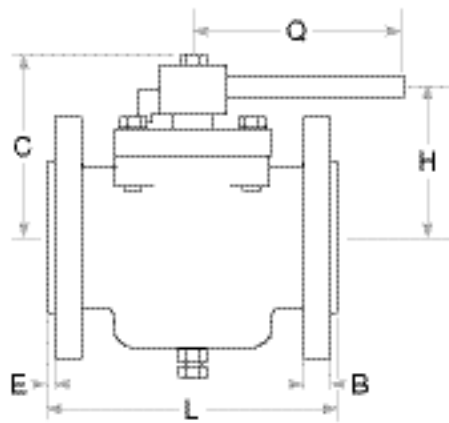

Flange bolting:
(N) Number of bolt holes
(O) Dia. of bolt holes
(P) Dia. of bolt circle

Class 150, 2-way, Fig. No. **061**
with enclosed gear

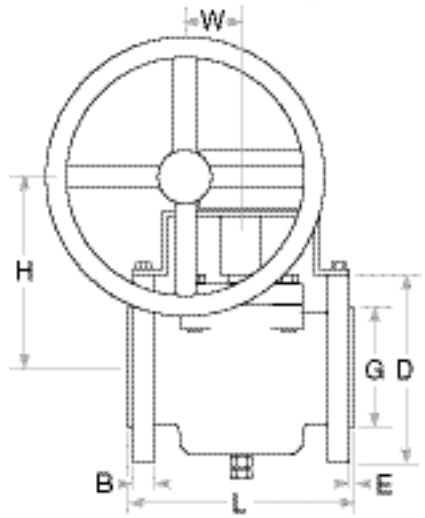

Class 300, 2-way, Fig. No. **0361**
with enclosed gear

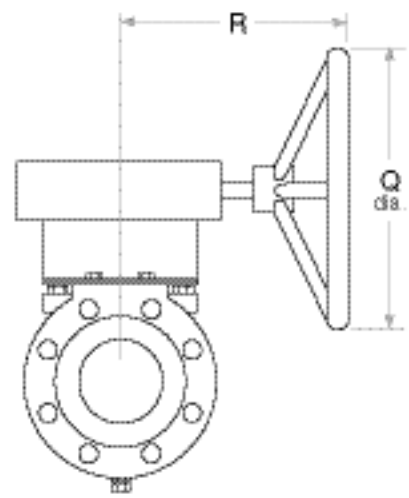
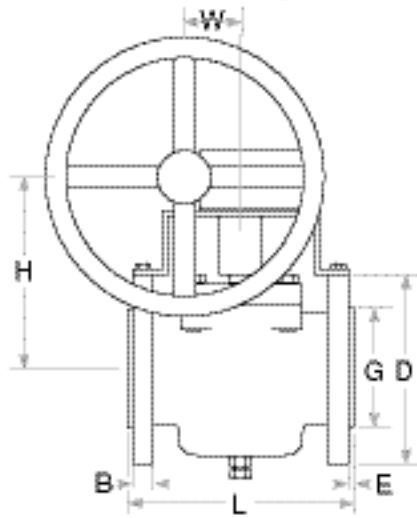

Class 150, 3-way, Fig. No. **031**

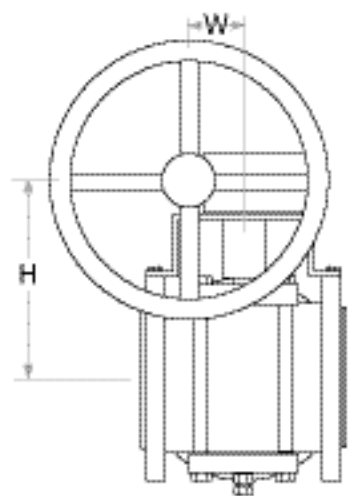
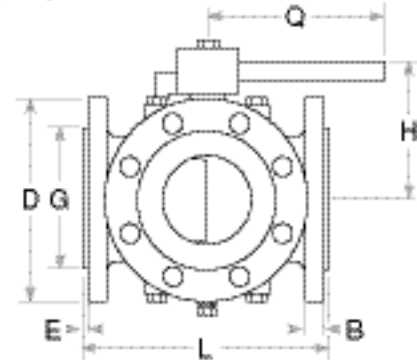
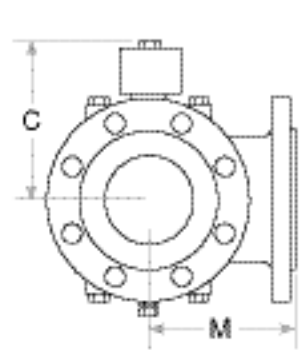

Dimensions with manual operators

Dimensions are in inches. Dimensions are nominal. For certified drawings contact factory.

Class 150, 2-way, Fig. No. 061 - with wrench

Size	L	C	H	D	B	G	E	Q	N	O	P	Wts.
1/2	4.25	4.03	3.09	3.50	.38	1.38	.09	7.75	4	.63	2.38	8
3/4	4.63	4.03	3.09	3.88	.41	1.68	.09	7.75	4	.63	2.75	9
1	5.00	3.75	2.88	4.25	.44	2.00	.19	7.75	4	.63	3.12	9
1 1/2	6.50	4.56	3.63	5.00	.56	2.88	.19	11.25	4	.63	3.88	15
2	7.00	5.13	4.00	6.00	.63	3.63	.19	17.00	4	.75	4.75	24
3	8.00	5.69	4.50	7.50	.75	4.75	.22	23.00	4	.75	6.00	30
4	9.00	7.06	5.75	9.00	.94	6.19	.22	29.00	8	.75	7.50	62

Class 150, 2-way, Fig. No. 061 - with enclosed gear

Size	L	H	D	B	G	E	Q	R	W	N	O	P	Wts.
4	9.00	8.75	9.00	.94	6.19	.22	12.00	8.00	2.06	8	.75	7.50	83
6	10.50	11.50	11.00	1.00	8.50	.15	18.00	10.38	2.62	8	.88	9.50	135
8	11.50	13.75	13.50	1.13	10.63	.16	18.00	10.38	2.62	8*	.88	11.75	229
10	13.00	13.38	16.00	1.19	12.75	.25	24.00	11.82	5.38	12*	1.00	14.25	362
12	14.00	15.13	19.00	1.25	15.00	.10	24.00	18.75	5.45	12*	1.00	17.00	516

*The 2 top and the 2 bottom flange holes are tapped for 3/4-10 UNC threads for 8" valves - 7/8-9 UNC threads for 10" & 12" valves.

Class 300, 2-way, Fig. No. 0361 - with wrench

Size	L	C	H	D	B	G	E	Q	N	O	P	Wts.
1	6.50	3.75	2.88	4.88	.69	2.00	.13	7.75	4	.75	3.50	13
1 1/2	7.50	4.56	3.63	6.12	.81	2.88	.13	11.25	4	.88	4.50	23
2	8.50	5.13	4.00	6.50	.88	3.63	.15	17.00	8	.75	5.00	32
3	11.13	5.69	4.50	8.25	1.12	5.00	.15	23.00	8	.88	6.63	42
4	12.00	7.06	5.75	10.00	1.25	6.19	.15	29.00	8	.88	7.88	88

Class 300, 2-way, Fig. No. 0361 - with enclosed gear

Size	L	H	D	B	G	E	Q	R	W	N	O	P	Wts.
4	12.00	8.75	10.00	1.25	6.19	.15	12.00	8.00	2.06	8	.88	7.88	117
6	15.88	11.50	12.50	1.44	8.50	.15	18.00	10.38	2.62	12	.88	10.63	221

Class 150, 3-way, Fig. No. 031 - with wrench

Size	L	C	H	D	B	G	E	Q	M	N	O	P	Wts.
1	5.00	3.75	2.88	4.25	.44	2.00	.13	7.38	3.50	4	.63	3.13	16
1 1/2	6.50	4.56	3.63	5.00	.56	2.88	.13	11.25	4.13	4	.63	3.88	21
2	7.00	5.13	4.00	6.00	.63	3.63	.15	23.00	4.50	4	.75	4.75	33
3	8.00	5.69	4.50	7.50	.75	4.75	.15	29.00	5.13	4	.75	6.00	47

Class 150, 3-way, Fig. No. 031 - with enclosed gear

Size	L	H	D	B	G	E	Q	R	M	W	N	O	P	Wts.
4	9.00	9.06	9.00	.94	6.19	.15	12.00	8.88	6.53	2.62	8	.75	7.50	96

2-way operating torques (inch-lbs) & Cv factors for sizing 2-way valves.

Size	061, 0361 Break Torques	Cv Factors
1/2	260	9
3/4	260	9
1	400	43
1 1/2	600	89
2	800	172
3	1200	294
4	1800	548
6	4800	1075
8	15000	1591
10	17000	2159
12	21000	3200

Pressure-temperature ratings.

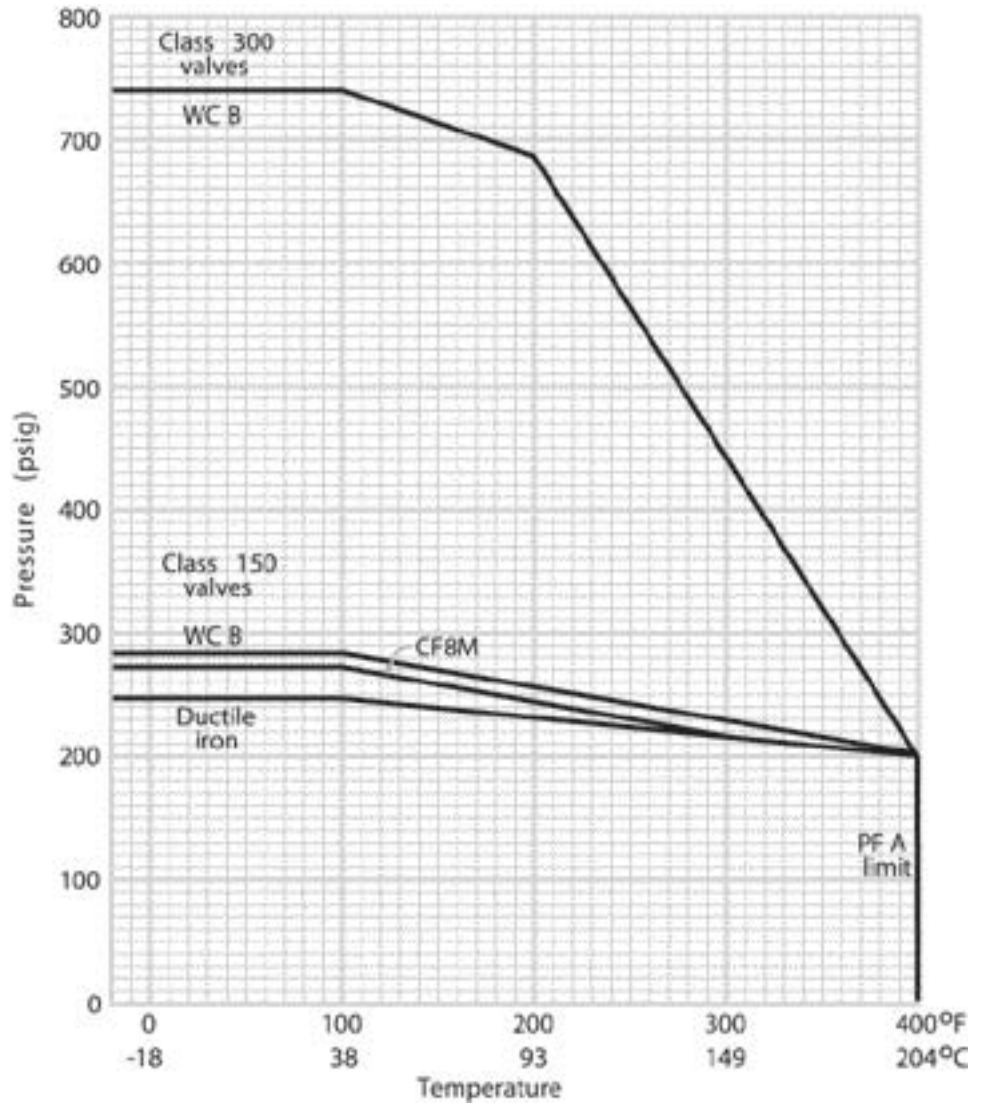

Methods of operation.

Wrench handles.

For valves 1-inch through 4-inch, a wrench handle is standard. The handle can be positioned for one-hand operation or as a "T" wrench for two-hand operation.

45° hubs.

Hubs can be supplied with the handle hole drilled at a 45° angle. This permits free movement of handles when valves are installed close together, as in a manifold.

The 45° angle is also useful for chain operation when the valve is installed in an elevated position on its side.

Hubs can be adapted to receive extended wrenches of desired heights for applications such as pit installations.

Wrench - hub configuration.

The wrench hub slips over the plug shank. It is keyed in place horizontally by the machined parallel flats at the top of the shank. It is locked in place by a vertical bolt through the hub cap and the wrench handle into the plug shank. The hub cap provides additional shielding protection for the valve and adjusting screws and also holds the wrench handle firmly in place. A nameplate is secured to the hub cap. It indicates the valve figure number, manufacture date, body material, plug material, valve size, ANSI class, maximum PSI/@max°F. On multiport valves, the direction of flow and type of plug are indicated.

Enclosed gear actuators.

Six and eight inch valves (and smaller valves if requested) are supplied with enclosed worm gear actuators. The figure numbers have the suffix "EG" to indicate enclosed gear actuation. This actuator includes a robust ductile iron housing, right angle gearing, factory lubrication, adjustable travel stops, and a handwheel. A crank handle is also available.

Actuators.

Tufline lined valves are easily adapted to various modes of remote pneumatic or electrical actuation. Flat mounting pads are cast in the top of each flange, making mounting of actuators easy and secure. Matryx® rack & pinion, vane, and electric actuators provide efficient quarter turn operation of Tufline lined valves.

Actuator mounting dimensions

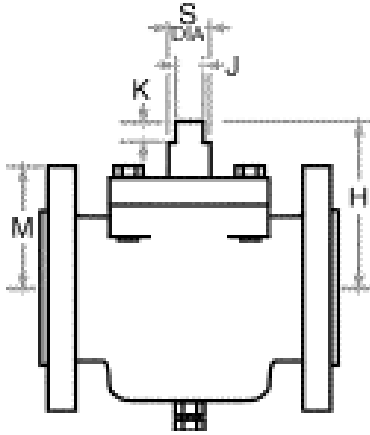

2 hole actuator mounting

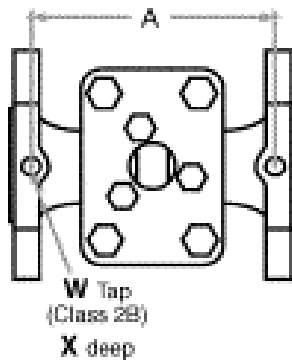

4 hole actuator mounting

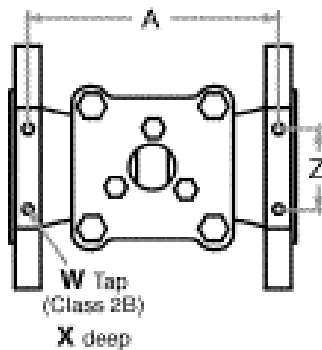

Size	H	K	J	S
1/2	2.75	.50	.438	.62
3/4	2.75	.50	.438	.62
1	2.50	.32	.438	.63
1 1/2	3.06	.44	.563	.88
2	3.56	.53	.750	1.13
3	4.13	.53	.750	1.13
4	5.03	.78	.875	1.25
6	7.35	1.00	1.398	2.00
8	9.44	1.00	1.673	2.50
10	10.81	1.00	1.673	2.50
12	11.75	1.00	1.968	3.00

Size	Fig. No. 061 M	Fig. No. 0361 M	Fig. No. 031 M
1/2	2.06	-	-
3/4	2.06	-	-
1	2.13	2.44	2.13
1 1/2	2.50	3.06	2.50
2	3.00	3.25	3.00
3	3.75	4.13	3.75
4	4.63	5.13	4.63
6	5.50	6.25	-
8	6.75	-	-
10	8.00	-	-
12	9.50	-	-

	Size	W	X	Z
2 Hole Pattern	1/2	5/16-18	.50	-
	3/4	5/16-18	.50	-
4 Hole Pattern	1	5/16-18	.38	1.75
	1 1/2	5/16-18	.47	1.75
	2	5/16-18	.47	2.25
	3	3/8-16	.56	3.50
	4	7/16-14	.63	4.00
	6	7/16-14	.63	4.00
	8	1/2-13	.63	6.00
	10	1/2-13	1.00	6.00
	12	1/2-13	1.00	6.00

Size	Fig. No. 061 A	Fig. No. 0361 A	Fig. No. 031 A
1/2	3.62	-	-
3/4	3.75	-	-
1	4.19	5.75	4.19
1 1/2	5.63	6.63	5.63
2	6.19	7.56	6.19
3	7.13	9.94	7.13
4	7.88	10.69	7.88
6	9.44	14.00	-
8	10.19	-	-
10	11.06	-	-
12	12.53	-	-

Full dimensions for valve and actuator assemblies are available.

Operating torques, port arrangements, and Cv factors for sizing 031 3-way valves.

Size	Break Torques (inch-lbs)
1	800
1½	1200
2	1600
3	2400
4	3600

C	Position 1, 0°	Position 2, 90°	Position 3, 180°
	Size	Cv factors	Cv factors
1	25	31	25
1½	47	52	47
2	87	105	87
3	123	160	123
4	211	335	211

AX	Position 1, 0°	Position 2, 90°
	Size	Cv factors
1	28	28
1½	50	50
2	90	90
3	164	164
4	275	275

D	Position 1, 0°	Position 2, 90°	Position 3, 180°
	Size	Cv factors	Cv factors
1	25	27	25
1½	47	50	47
2	87	94	87
3	123	133	123
4	211	228	211

Quality assurance.

Tufline liners are dielectrically spark tested at 20,000 volts in accordance with ASTM D5162 specifications.

Valves are available specifically tested and tagged to indicate conformity to ANSI B16.34 or B16.42 shell tests and MSS SP-61 seat test requirements.

Actuators.

Tufline fully lined valves can be supplied with a variety of manual, pneumatic or electric actuators.

Vacuum service.

Tufline fully lined valves are satisfactory for vacuum service as low as .01 microns in absolute pressure. However, special cleaning is required to achieve this rating. Vacuum ratings have been established by independent laboratories using helium leak tests on mass spectrometers.

Custom designs and modifications.

The products featured in this catalog may be obtained in other sizes and materials from the Tufline Special Products Group, which offers design, engineering and manufacturing services for custom products and modifications.

Oxygen and chlorine valves.

Valves designated for oxygen or chlorine service are thoroughly cleaned, tested and dried per internal Tufline oxygen and chlorine standards. Flanges are then sealed and valves are packaged in plastic containers.

Locking device.

Tufline lined plug valves can be supplied with a variety of locking devices: plate locking device (PLD), extended locking device (ELD), and low profile locking device (LLD).

Quick reference selection table.

No. of Ports	ANSI Class	Liner	Size Range	Body	Plug	Figure Number
2	150	PFA	1/2 - 12	316SS	316SS	061
			1/2 - 3/4	DI	CD4MCu	061
			1 - 8	DI	DI	061
			10 - 12	WCB	DI	061
3	300	PFA	1 - 6	WCB	DI	0361
	150		1 - 4	DI	DI	031

* Contact factory for alternative materials

How To Specify

Size Figure No. Options Body Body Liner Plug Plug Liner Operator Service

3" - 061 - TFM - 1 - P6 - 1 - P6 - W - C

Size & Figure No.

ANSI 150 1/2" - 12" **061**
 ANSI 300 1/2" - 10" **0361**
 ANSI 150, 3-Way 1" - 4" . **031**

Options

Port Arrangements
 for 3-way valves
 (See page 10) . . **AX, C, or D**
 Tertiary Top Seal **TS**
 Tuffline-475 Top Seal . . . **TFM**
 Ends prepared for
 Resistoflex HIF system . . **HIF**
 No Options **Blank**

Body

Ductile Iron . . . **1**
 Carbon Steel . . **2**
 316 Stainless . . **6**
 Alloy 20 **0**
 CD4MCu **27**
 Other **X**

Body Liner

PFA **P6**
 PFA (Unpigmented) . **P6X**

Plug

Alloy 20 **0**
 Ductile Iron . . . **1**
 Carbon Steel . . **2**
 316 Stainless . . **6**
 Hastelloy B . . . **8**
 Hastelloy C . . . **9**
 CD4MCu **27**
 Titanium **33**
 Other **X**

Service

Chlorine . . **C**
 Oxygen . . **O**
 Vacuum . . **V**
 General Service . . . **Blank**
 Other **X**

Operator

No operator . . **N**
 Wrench **W**
 Wrench with extended hub . . . **EH**
 Wrench with locking device . . . **WY**
 Wrench with extended locking device . **ELD**
 Gear **G**
 Gear with locking device **GZ**
 Actuator* . . . **A**
 Other **X**

Plug Liner

PFA **P6**
 PFA (Unpigmented) . **P6X**
 Unlined plug **0**

* Specify actuator type and air supply.

Global Capabilities For Global Customers

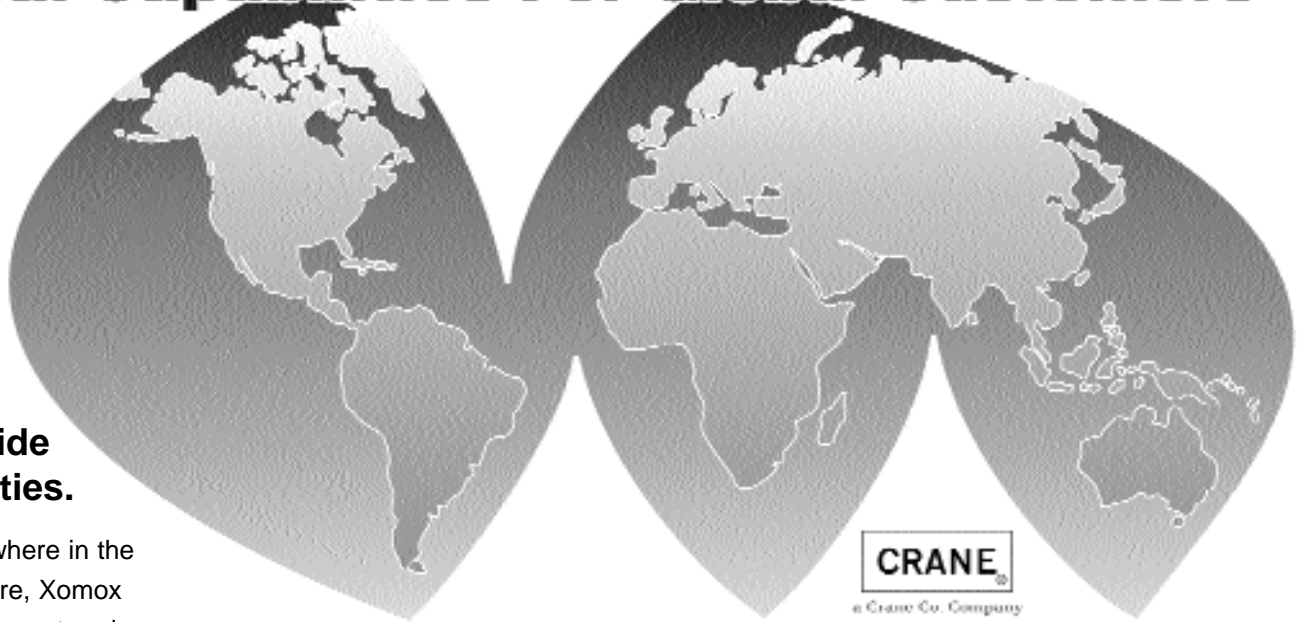

Worldwide capabilities.

No matter where in the world you are, Xomox technical support and services are available from:

- 16 Manufacturing Facilities
- 18 Service Centers
- 50 Sales Offices
- More than 200 Xomox Authorized Distributors

Product selection.

Xomox offers the broadest line of process valves, actuators, accessories, and related services including:

- Tufline® Process Valves
- Saunders Diaphragm Valves
- Matryx® Rack & Pinion, Vane Actuators
- Xomox® XRP™ Actuators

Product responsibility.

Xomox's concern for product performance extends to the product's period of service. We feel it is important for users to also be aware of their responsibilities. Our products are manufactured and used in numerous applications with a wide variety of service conditions. While general guidelines are often furnished, it obviously is not possible to provide complete and specific performance data for every conceivable service condition.

Global locator.

For a listing of Xomox Manufacturing Facilities, Service Centers, Regional Offices, and Authorized Distributors, visit our web site www.xomox.com.

Xomox literature.

All Xomox catalogs and technical data are available as PDF files at www.xomox.com.

Phone support.

Call your nearest Xomox Sales Office or the Xomox World Headquarters:
Phone: 513-745-6000
Fax: 513-745-6093

Corporate strength.

Xomox is a Crane Co. company. Through the Crane Co. association, Xomox offers even greater global capabilities and breadth of product lines.

Xomox Corporation

World Headquarters
4444 Cooper Road
Cincinnati, Ohio 45242

XOMOX
Process Valves & Actuators

Therefore, the end user must assume final responsibility for proper evaluation, application and performance of all products. The contents of this document are presented for information purposes only. Every effort has been made to ensure accuracy. This information is not intended to be construed as warranties or guarantees, expressed or implied, nor imply use applicability, for products or services described herein.

We reserve the right to modify or

improve the designs and specifications of such products at any time without notice. As the manufacturer, Xomox sells its products and services pursuant to its standard terms and conditions of sale, including its limited warranty, copies of which are available upon request. Xomox limits its liability specifically to the replacement or repair of defective items, or to a refund for same. Xomox does not accept liability for any incidental or consequential damages.