

# **Tufline Jacketed Valves**

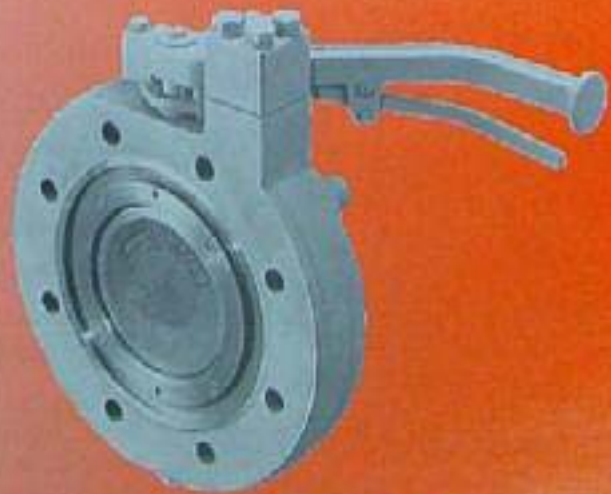
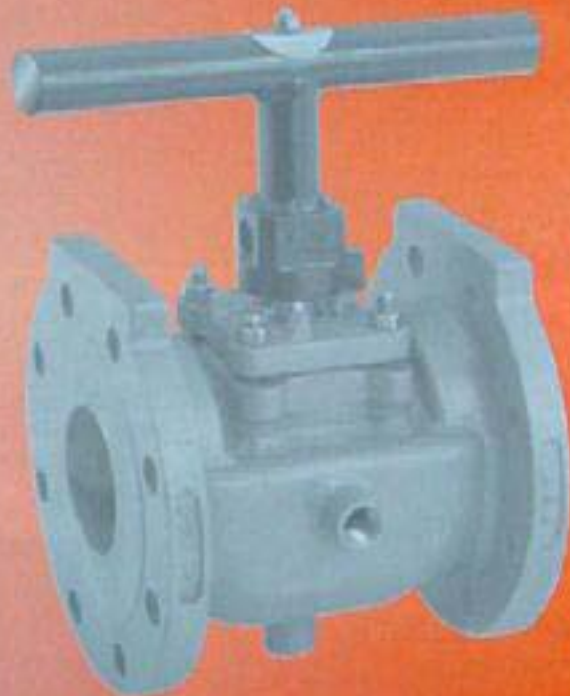

**XOMOX**  
Process Valves & Actuators

# Innovative valves for critical temperature control.

Choose from a broad range of Tufline® valves specifically designed for handling temperature-sensitive fluids.

	Page
Jacketed Sleeved Plug Valves . . . . .	3
Jacketed Metal Seated Plug Valves . . . . .	6
Steam Traced Butterfly Valves . . . . .	8
Jacketed Rail Tank Car Butterfly Valves . . . . .	11
Matryx® Actuators Service Centers Special Products . . . . .	14



## Worldwide capabilities pay off for Tufline customers.

With facilities in a dozen countries around the world, Xomox has unique capabilities for global sourcing of the latest technologies, innovative materials, and the most sophisticated manufacturing techniques.

The Xomox team turns these resources into problem-solving valves for your most demanding applications.

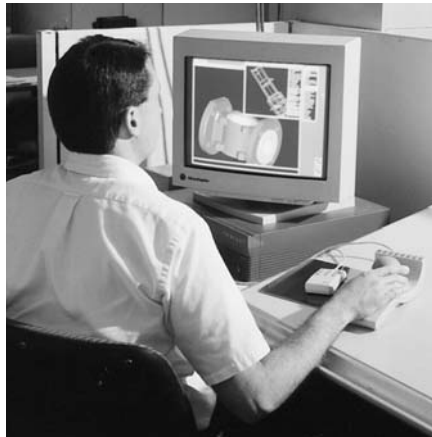

## Knowledgeable people.

The Xomox team works with you to assure optimum valve performance.

Your Xomox support team includes Sales Engineers, Authorized Distributors, Service Center Technicians, and Application Specialists.



## Problem solvers.

Talk with a Xomox Sales Engineer about any aspect of your fluid handling system. You will get process-improving answers.

Your Xomox Sales Engineer has the proven products and is backed by the technical expertise to help solve your toughest fluid handling problems.



## Customer focus, customer satisfaction.

Xomox strives to fully understand your unique needs, and cost-effectively fulfill your requirements.

Processors know they can depend on Xomox for trouble-free fluid control equipment and superior service.

© Copyright Xomox Corporation 1965, 2005. All rights reserved. Xomox®, Tufline®, and Matryx® are registered trademarks of Xomox Corporation. XRP™ is a trademark of Xomox Corporation.

# Jacketed Sleeved Plug Valves

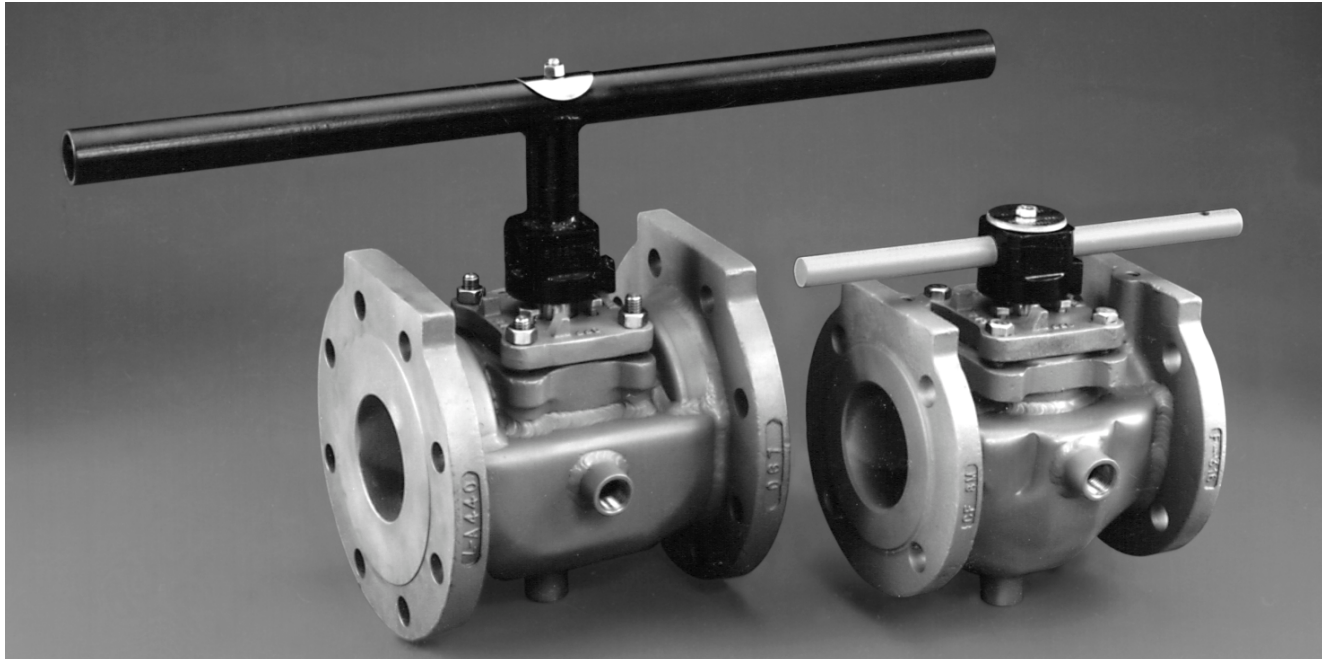

**Tufline Jacketed Sleeved Plug Valves offer all the attributes of Standard Tufline Sleeved Plug Valves.**

360° lips break up and remove adhering, scaly deposits from the outer surface of the plug as it rotates.

Tufline Sleeved Plug Valves provide superior sealing, exceptional emissions control, ease of automation, and long-term reliability . . . all at a standard valve price.

For superior in-line sealing, the locked-in PTFE sleeve completely surrounds the plug. Tight sealing is assured because of the concentrated compression of the sleeve's large circumferential sealing surface against high-pressure ribs.

Tufline Sleeved Plug Valves provide primary and secondary sealing elements to prevent leakage along the stem to the atmosphere.

These valves can be operated with simple, standard quarter-turn actuators. Because of the lubricity of the PTFE sleeve, they open and close easily, even after not being operated for greatly extended periods of time.

No. of Ports	Jacket Type	ANSI Class	Size Range	Operator	Figure Number
2	Partial Jacket	150	1 - 4	Wrench	067PJ
			4 - 12	Enclosed Gear	067PJ-EG
		300	1 - 4	Wrench	0367PJ
			4 - 12	Enclosed Gear	0367PJ-EG
	Full Jacket	150	2x1x2 - 6x4x6	Wrench	067FJ
			6x4x6 - 12x10x12	Enclosed Gear	067FJ-EG
		300	2x1x2 - 6x4x6	Wrench	0367FJ
			6x4x6 - 12x10x12	Enclosed Gear	0367FJ-EG
3	Partial Jacket	150	1 - 4	Wrench	037PJ
			4 - 12	Enclosed Gear	037PJ-EG
		300	1 - 4	Wrench	0337PJ
			4 - 12	Enclosed Gear	0337PJ-EG

All jackets are rated at 235 psi to 400°F. Standard jacketed valve bodies are available in carbon steel or 316 stainless steel.

Dimensional data is on the following page.

# Jacketed Sleeved Plug Valve Dimensions Dimensions are in inches. Weights are in pounds.

For actuator mounting dimensions, other additional dimensions, and full specifications, see the Tufline Sleeved Plug Catalog #329703.

Additional information is also available at [www.xomox.com](http://www.xomox.com). You can also contact your nearest Xomox representative.

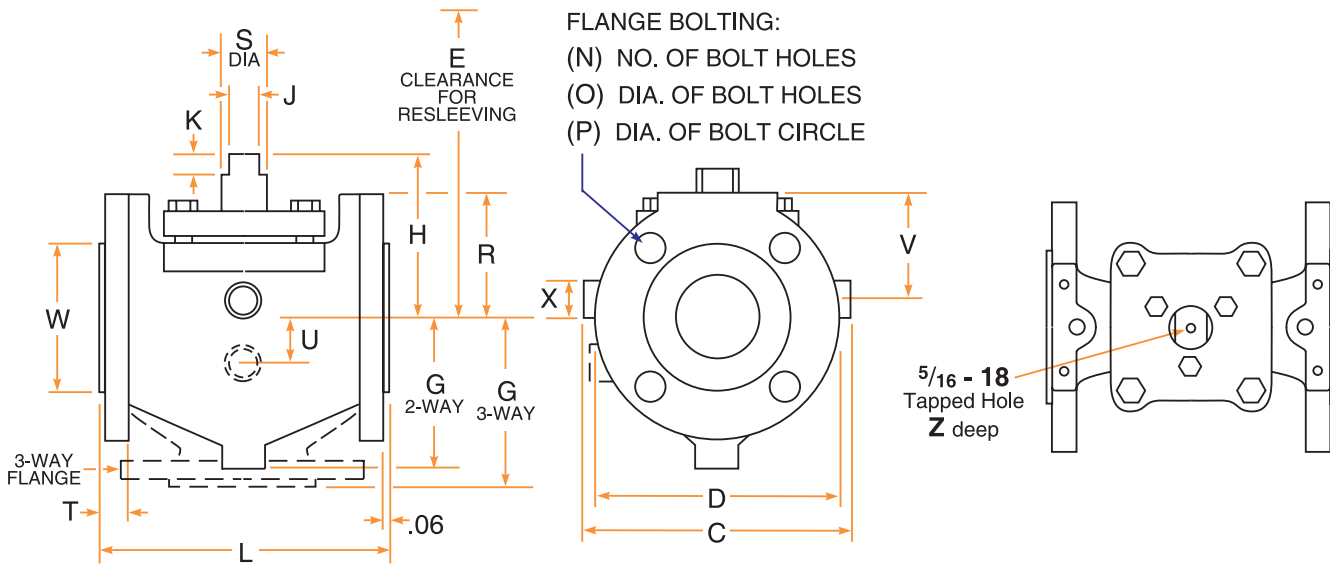

## Partial Jacket - Class 150 . . . 2-Way: Figure No. 067PJ . . . 3-Way: Figure No. 037PJ

Size	L	D	W	C	T	R	N	O	P	H	S	J	K	E	V	X**	U 3-Way	G 2-Way	G 3-Way	Weight 2-Way	Weight 3-Way
1	5.00	4.25	2.00	4.80	.44	2.13	4	.63	3.13	2.50	.63	.438	.32	7.00	2.72	3/8	-	3.04	3.50	8.5	11
1½	6.50	5.00	2.88	6.22	.56	2.50	4	.63	3.88	3.06	.88	.563	.44	8.00	2.66	½	-	3.54	4.13	16	20
2	7.00	6.00	3.63	7.00	.63	3.00	4	.75	4.75	3.56	1.13	.750	.53	9.13	3.28	½	-	4.01	4.50	24	30
2½†	8.00	7.50	4.13	7.86	.75	3.75	4	.75	5.50	4.13	1.13	.750	.53	10.13	3.22	½	-	4.70	5.13	36	47
3	8.00	7.50	5.00	7.86	.75	3.75	4	.75	6.00	4.13	1.13	.750	.53	10.13	3.22	½	1.47	4.70	5.13	36	47
4	9.00	9.00	6.19	9.76	.94	4.63	8	.75	7.50	5.22	1.25	.875	.78	22.00	4.10	½	3.47	5.51	6.00	62	77
6	10.50	11.00	8.50	9.94	1.00	5.50	8	.88	9.50	7.35	2.00	1.389	1.00	25.00	4.35	1	4.85	6.86	7.50	105	129
8	11.50	13.50	10.63	10.58	1.13	6.75	8*	.88	11.75	9.32	2.00	1.389	1.00	28.00	3.05	1	-	8.68	9.00	190	-
10	13.00	16.00	12.75	13.99	1.19	8.00	12*	1.00	14.25	10.81	2.50	1.673	1.00	29.00	7.38	1	-	9.18	11.00	280	-
12	14.00	19.00	15.00	13.99	1.25	9.50	12*	1.00	17.00	11.81	3.00	1.968	1.00	35.00	7.77	1	-	11.27	-	380	-

## Partial Jacket - Class 300 . . . 2-Way: Figure No. 0367PJ . . . 3-Way: Figure No. 0337PJ

Size	L	D	W	C	T	R	N	O	P	H	S	J	K	E	V	X**	U 3-Way	G 2-Way	G 3-Way	Weight 2-Way	Weight 3-Way
1	6.50	4.88	2.00	4.80	.69	2.44	4	.75	3.50	2.50	.63	.438	.32	7.00	3.03	3/8	-	3.04	3.75	13	17
1½	7.50	6.13	2.88	6.22	.81	3.06	4	.88	4.50	3.06	.88	.563	.44	8.00	3.22	½	-	3.54	4.38	24	32
2	8.50	6.50	3.63	7.00	.88	3.25	8	.75	5.00	3.56	1.13	.750	.53	9.13	3.53	½	-	4.01	4.75	32	41
2½†	11.13	8.25	4.13	7.86	1.13	4.13	8	.88	5.88	4.13	1.13	.750	.53	10.13	3.60	½	-	4.70	5.56	43	58
3	11.13	8.25	5.00	7.86	1.13	4.13	8	.88	6.63	4.13	1.13	.750	.53	10.13	3.60	½	1.47	4.70	5.56	43	58
4	12.00	10.00	6.19	9.76	1.25	5.13	8	.88	7.88	5.22	1.25	.875	.78	22.00	4.60	½	3.47	5.51	6.75	88	113
6	15.88	12.50	8.50	9.94	1.44	6.25	12	.88	10.63	7.35	2.00	1.389	1.00	25.00	5.10	1	4.85	6.86	8.50	175	217
8	16.50	15.00	10.63	10.58	1.63	7.50	12	1.00	13.00	9.32	2.00	1.389	1.00	28.00	3.80	1	-	8.68	-	282	-
10	18.00	17.50	12.75	13.99	1.88	8.75	16	1.13	15.25	10.81	2.50	1.673	1.00	29.00	8.13	1	-	9.18	-	415	-
12	19.75	20.50	15.00	13.99	2.00	10.25	16	1.25	17.25	11.81	3.00	1.968	1.00	35.00	8.52	1	-	11.27	-	565	-

\* On the valves where the "N" dimension is asterisked, the two top holes only are tapped as follows:  
 8-inch valves: 3/4-10UNC-2B . . . 10-inch & 12-inch valves: 7/8-9UNC-2B

† 2½-inch valves are machined from 3-inch castings, but the flanges are machined to 2½-inch dimensions.

\*\* X - NPT - 3 steam ports.  
 3-Way 1, 2, & 2½ inch valves have only 2 steam ports.

### Full Jacket - Class 150 . . . 2 Way: Figure No. 067FJ

Size	L	D	W	C	T	R	N	O	P	H	S	J	K	E	V	X	G 2-Way	Weight 2-Way
2 x 1 x 2	7.00	6.00	3.63	5.92	.62	3.00	4	.75	4.75	2.50	.63	.438	.32	7.00	3.16	1/2	3.15	22
2 1/2 x 1 1/2 x 2 1/2	7.50	7.00	4.13	6.44	.68	3.50	4	.75	5.50	3.06	.88	.563	.44	8.00	4.09	1/2	3.69	32
3 x 2 x 3	8.00	7.50	5.00	7.78	.75	3.75	4	.75	6.00	3.56	1.13	.750	.53	9.13	3.73	1/2	3.70	35
4 x 3 x 4	9.00	9.00	6.19	7.40	.94	4.63	8	.75	7.50	4.13	1.13	.750	.53	10.13	4.60	1/2	4.63	58
6 x 4 x 6	10.50	11.00	8.50	8.18	1.00	5.50	8	.88	9.50	5.22	1.25	.875	.78	22.00	5.43	1	5.77	102
8 x 6 x 8	11.50	13.50	10.63	9.56	1.13	6.75	8	.88	11.75	7.35	2.00	1.40	1.00	25.00	5.48	1	5.29	185
10 x 8 x 10	13.00	16.00	12.75	11.00	1.19	8.00	12	1.00	14.25	9.32	2.00	1.389	1.00	28.00	5.56	1	8.12	247
12 x 10 x 12	14.00	19.00	15.00	11.00	1.25	9.50	12	1.00	17.00	10.81	2.50	1.673	1.00	29.00	4.72	1	8.38	355

### Full Jacket - Class 300 . . . 2 Way: Figure No. 0367FJ

Size	L	D	W	C	T	R	N	O	P	H	S	J	K	E	V	X	G 2-Way	Weight 2-Way
2 x 1 x 2	7.50	6.50	3.63	5.92	.88	3.25	8	.75	5.00	2.50	.63	.438	.32	7.00	3.41	1/2	3.15	30
2 1/2 x 1 1/2 x 2 1/2	8.13	7.58	4.13	6.44	1.00	3.75	8	.88	5.88	3.06	.88	.563	.44	8.00	4.34	1/2	3.69	38
3 x 2 x 3	8.75	8.25	5.00	7.78	1.13	4.13	8	.88	6.63	3.56	1.13	.750	.53	9.13	4.11	1/2	3.70	42
4 x 3 x 4	9.63	10.00	6.19	7.40	1.25	5.00	8	.88	7.88	4.13	1.13	.750	.53	10.13	4.98	1/2	4.63	84
6 x 4 x 6	11.38	12.50	8.50	8.18	1.44	6.25	12	.88	10.63	5.22	1.25	.875	.78	22.00	6.18	1	5.77	170
8 x 6 x 8	12.50	15.00	10.63	9.56	1.63	7.50	12	1.00	13.00	7.35	2.00	1.40	1.00	25.00	6.23	1	5.29	265
10 x 8 x 10	16.50	17.50	12.75	13.50	1.88	8.75	16	1.12	15.25	9.32	2.00	1.389	1.00	28.00	5.50	1	8.94	377
12 x 10 x 12	18.00	20.50	15.00	11.50	2.00	10.25	16	1.25	17.75	10.81	2.50	1.673	1.00	29.00	5.57	1	10.25	508

Both larger and smaller sizes are available on request.

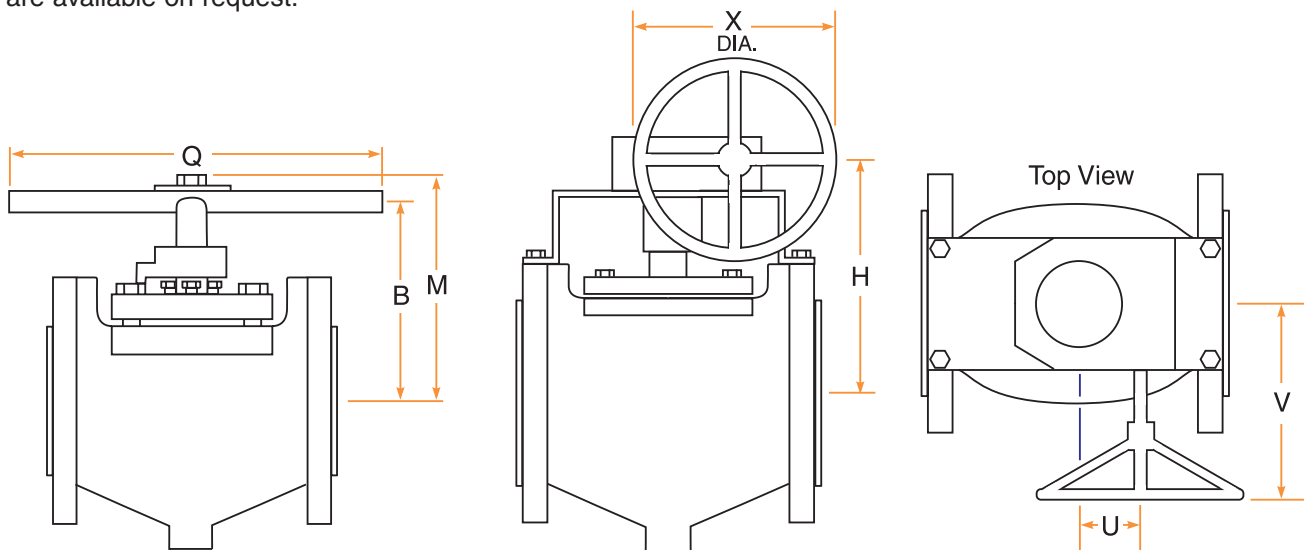

### Wrench & Enclosed Gear Operator Dimensions

These operator dimensions apply to fully jacketed 2-way and 3-way valves only. Partially jacketed valve operator dimensions are the same as a non-jacketed standard valves. See Catalog #329703.

Size	B	M	Q
2 x 1 x 2	6.50	7.43	12.00
2 1/2 x 1 1/2 x 2 1/2	7.12	8.05	16.00
3 x 2 x 3	7.88	9.01	24.00
4 x 3 x 4	8.44	9.50	24.00
6 x 4 x 6	9.60	10.91	36.00

Size	H	U	V	X
6 x 4 x 6	8.75	2.06	8.00	12.00
8 x 6 x 8	11.50	2.62	10.38	18.00
10 x 8 x 10	13.50	2.62	10.38	18.00
12 x 10 x 12	15.25	3.53	12.31	24.00

### More information.

In the Tufline Sleeved Plug Valve catalog you will find:

- Pressure-temperature ratings
- Cv factors
- Operating torques
- Actuator mounting dimensions
- A comprehensive listing of options, body materials, plug materials, sleeve materials, and operators
- Comprehensive ordering guidelines

# Jacketed Metal-Seated Plug Valves



These valves are normally supplied non-lubricated with metal-to-metal hand lapped seating. There are no liners or separable seats in which fluids can lodge and degrade. Two, three, and four-way valves are available. Lubricated models are also available.

*This extra heavy plug shank protects against damage from excessive torque.*

*Extra deep stuffing boxes with more packing provide better sealing.*

*Smooth internal contours and 100% flow area minimize pressure drop.*

*A tight metal-to-metal seal.  
(Media must have a viscosity of 500 centipoise or greater to assure a tight seal.)*

*The full jacket extends from flange to flange and fully around all fittings. This maximum heat transfer area assures rapid consistent heating.*

*The external adjusting screw regulates plug seating and allows easy disassembly.*

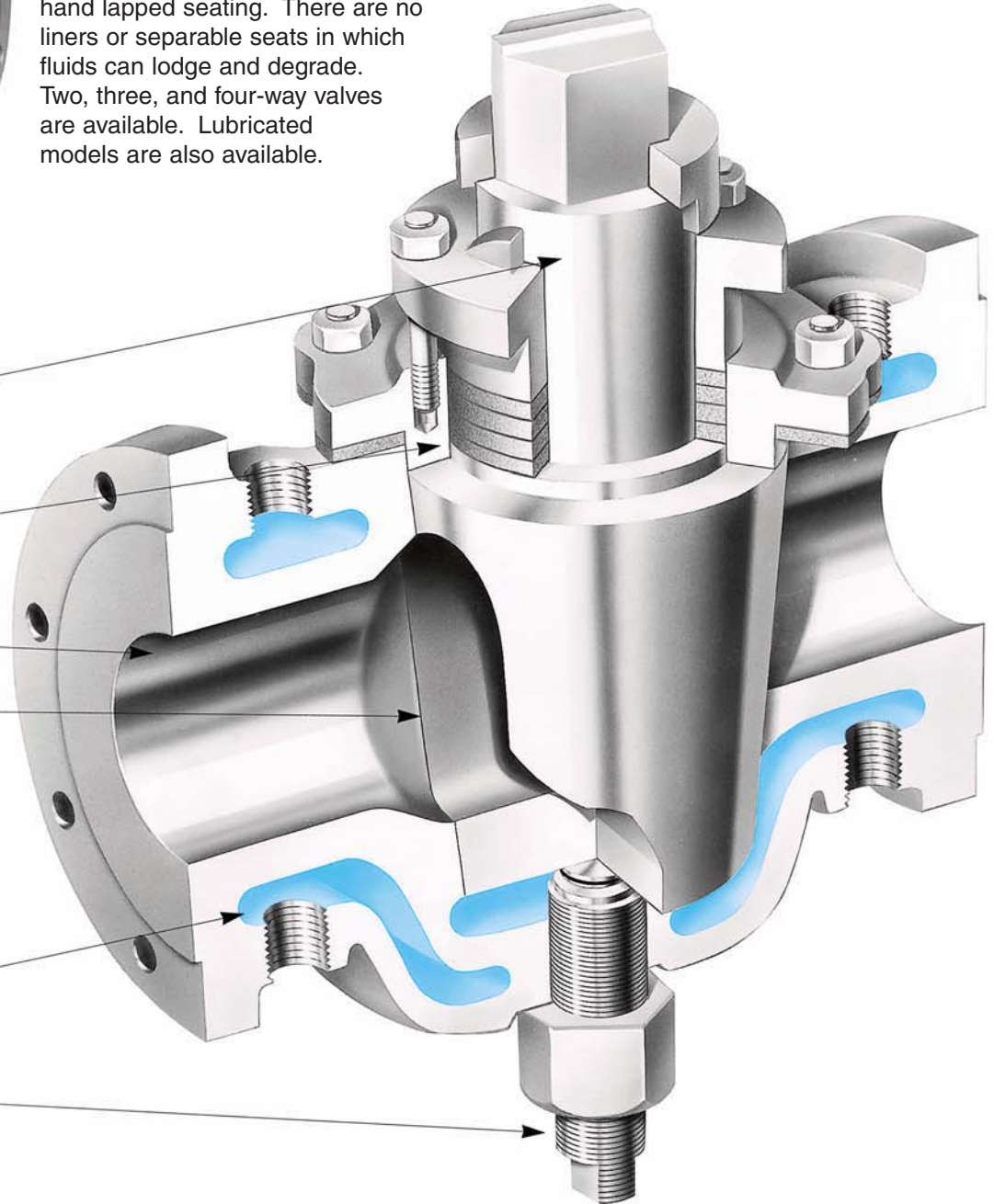

**Typical applications:**

pitch  
sulfur  
resins  
adhesives  
foods  
molten nylon  
polypropylene  
polyesters  
polymers

**Materials:**

WCB with stainless steel trim.  
Other materials available upon request.

**Pressure classes:**

ANSI B16.34 Classes 125, 150, and 300 are standard. Other classes are available upon request.

**Temperature rating:** Up to 650°F.

**Sizes:**

1-inch to 8-inches are standard.  
Other sizes available.

**Operators:**

Wrench handle to 4 inches.  
Geared, 6 inches and above.  
Air and electric actuation available.

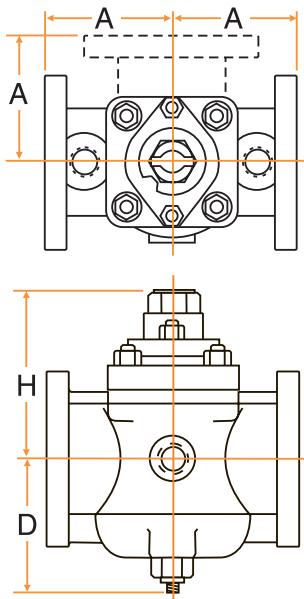

**Dimensional Data (inches)**

Class 125 & 150, 2-Way Valves

Size	A	D	H
1 x 2	4.50	4.88	5.44
1 1/4 x 2	4.50	4.88	5.44
1 1/2 x 2 1/2	5.00	5.50	6.38
2 x 3	5.50	6.12	7.25
3 x 4	6.50	8.38	9.88
4 x 6	8.00	8.88	11.50
6 x 8	9.00	11.62	13.44
8 x 10	11.00	14.62	19.19

Class 300, 2-Way Valves

Size	A	D	H
1 x 2	4.62	4.88	5.44
1 1/4 x 2	4.62	4.88	5.44
1 1/2 x 2 1/2	5.25	5.50	6.38
2 x 3	5.75	6.12	7.25
3 x 4	6.75	8.38	9.88
4 x 6	8.31	8.88	11.50
6 x 8	9.44	11.62	13.44
8 x 10	11.50	14.62	19.19

**How to order:**

Specify size, figure no., CB, pressure class, material, operator, and any special features required.

Example:

2x3 - CB125 - WCB/316 - Wrench

**Valve type selection:**

Within its temperature and pressure limits the jacketed sleeved plug valve performs better than the metal seated valve. The chart at the right shows the general operating parameters for both valve types.

Sleeved Plug Valves

Metal Seated Plug Valves

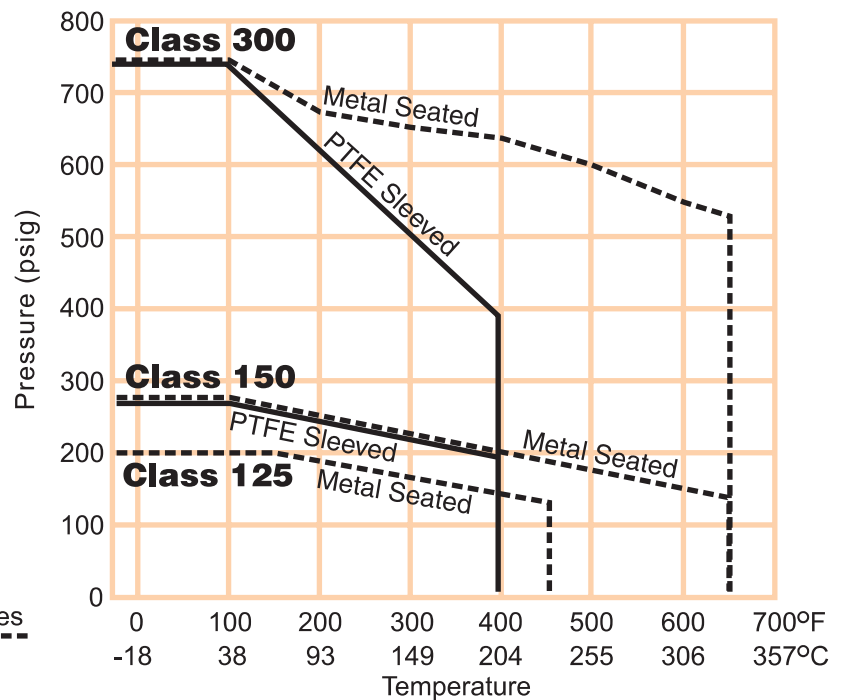

# Steam Traced Butterfly Valves

## Patented design.

A number of patents make this valve unique and unmatched for handling temperature sensitive fluids.

Accumulation of sulfur and similar fluids is virtually eliminated.

## Triple-point protection.

The Tufline Steam Traced Valve is the only valve that provides triple-point prevention of media solidification:

- Both the shaft and bearing area are fully heated.
- The steam is channeled from the shaft, around the full perimeter of the disc, and out the bottom shaft.
- A separate steam path circulates through each side of the body assuring complete and maximum temperature control.

## Integral jacket.

The Tufline integral body jacket assures more efficient and economical heating.

Because the jacket is integral there is no chance of faulty field installation of the jacket.

## Conventional jacketing failure.

Add-on jackets often have air spaces (cold spots) between the jacket and the valve body. These cold spots can allow media to solidify and accumulate.

Shafts and discs are far from the heat source, so media buildup is prevalent on these surfaces.

Conventional jacketing is grossly inefficient because of poor heat transfer.

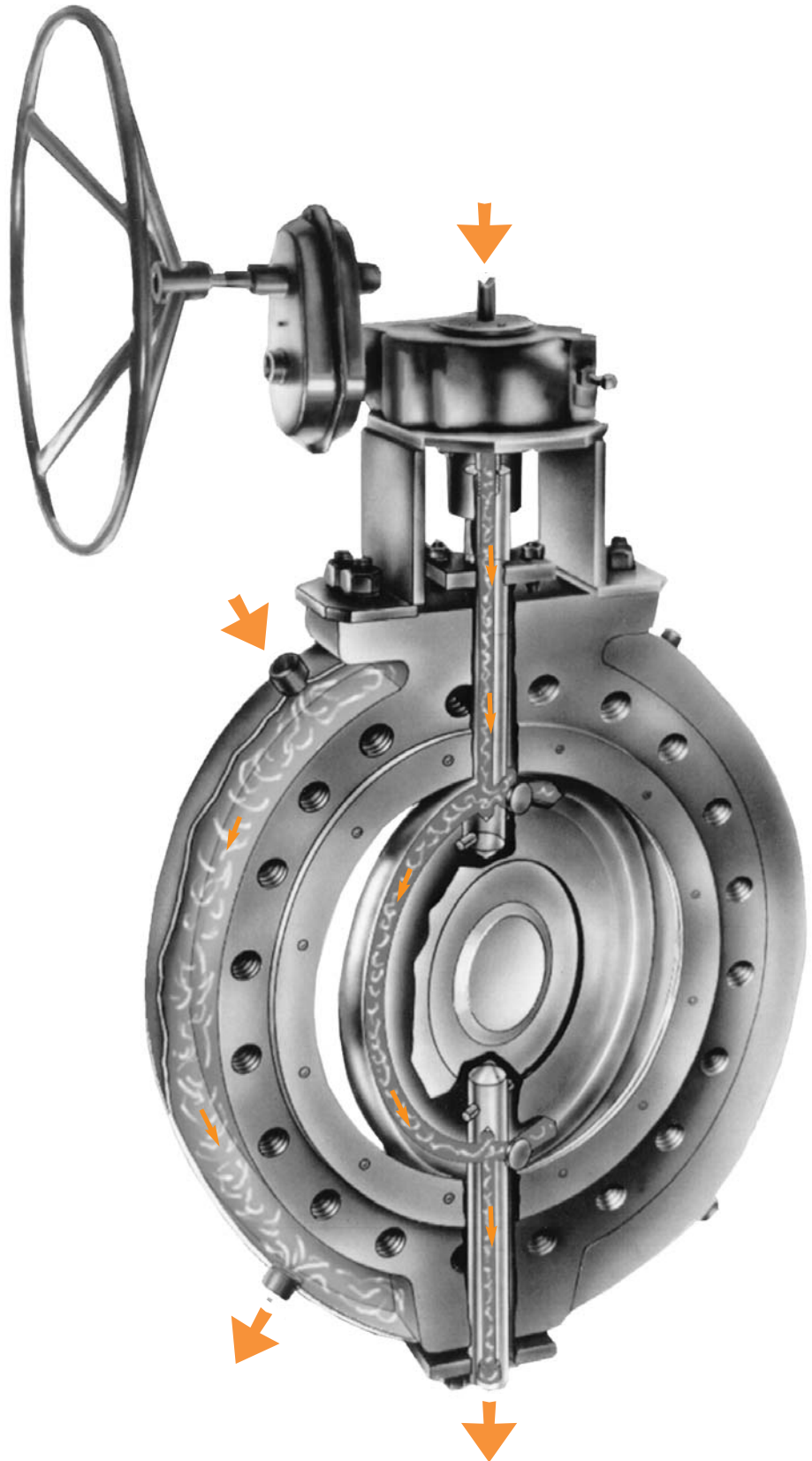



## Unique features in a wide range of configurations and options.

- Sizes 6 through 72 inch
- ANSI B16.34 Class 150, 150DR, 300, and 600
- Integral, full-body steam jacket
- Integral steam tracing of shafts and disc circumference
- Optional NACE trim
- Optional bearing purge (steam or alternate media)
- Optional sealed bearings
- Optional double-packed stems with lantern rings
- Optional fire tested and high-temperature seat designs

## More information.

In the Tufline High Performance Butterfly Valve Catalog you will find:

- Pressure temperature ratings
- Breakaway torques
- Component materials of construction
- A full selection of options
- Ordering instructions

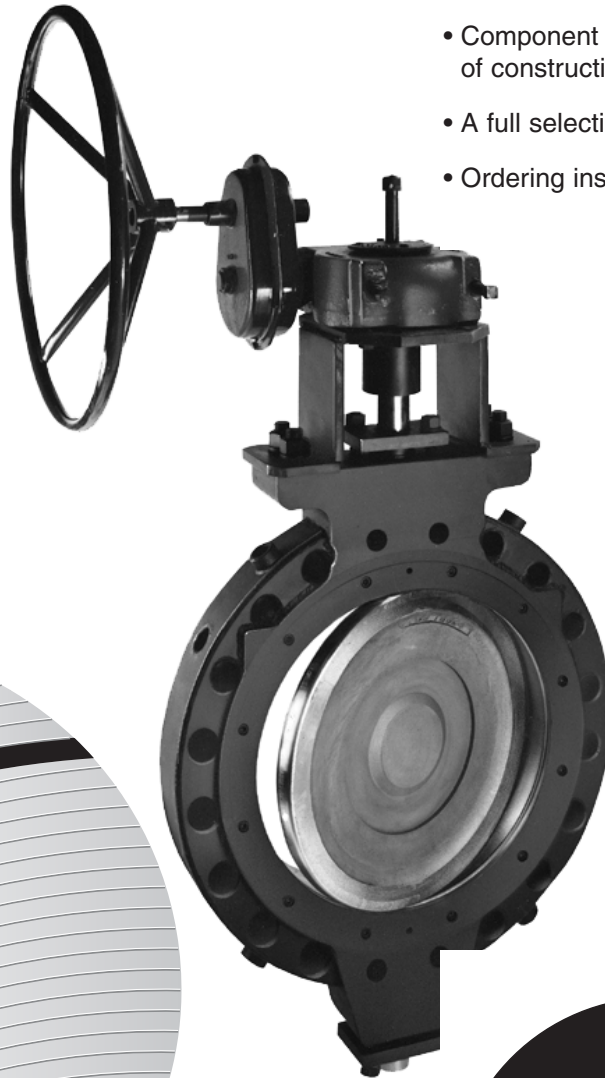

The patented seat is axially pliant. Unlike other seats, there is no radial stretch. When the valve opens, the seat flexes axially, returning to its original compact shape. It does not “relax” into the flow path.

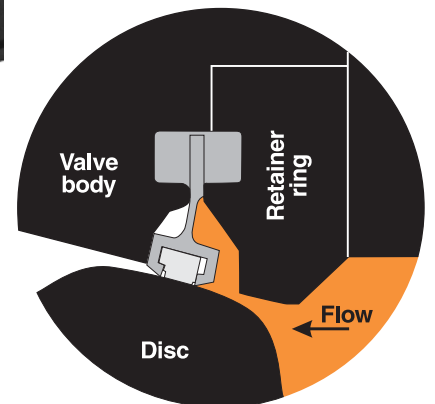
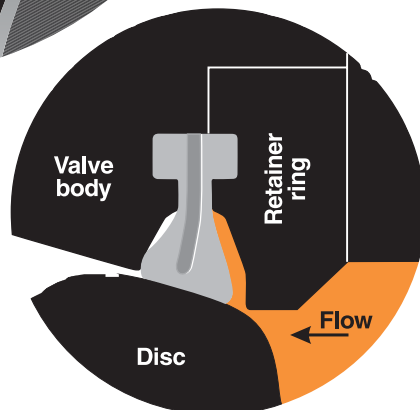

The seat is also available in fire-tested and high-temperature models.

Dimensions are on the following page.

# Steam Traced Butterfly Valve Dimensions

2-inch through 4-inch valves are steam jacketed around the body only.

Valves 6-inches and larger are steam traced both around the body as well as through the shaft and around the disc.

E: Diameter of flange bolt circle.  
 F: Number of flange bolts.  
 G1: Flange bolt size.  
 G2: Flange bolt drill through size for wafer mounting.

R: Number of actuator mounting holes.  
 S: Size of actuator mounting holes.  
 T: Depth of actuator mounting holes.

Weights (Wt.) are in pounds.

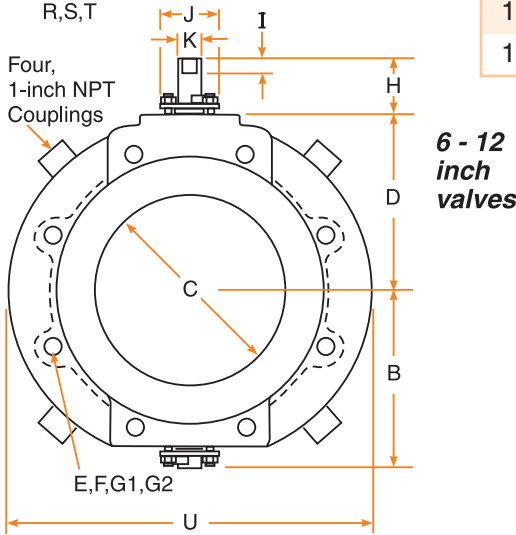
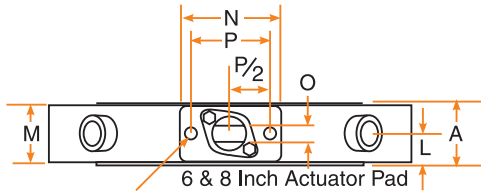
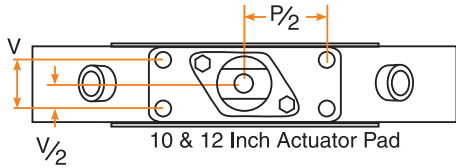

Size	A	B	C	D	E	F	G1	G2	H	I	J	K
6	2.25	5.94	5.77	6.00	9.50	8	3/4-10	7/8	3.25	1.00	1.98	.75
8	2.50	7.19	7.45	7.12	11.75	8	3/4-10	7/8	3.25	1.00	2.31	1.00
10	2.81	8.78	9.27	9.00	14.25	12	7/8-9	1	3.50	1.00	2.43	1.25
12	3.19	9.88	11.05	10.00	17.00	12	7/8-9	1	3.50	1.50	3.45	1.50

Size	L	M	N	O	P	R	S	T	U	V	Wt.
6	1.19	2.00	4.00	.56	3.13	2	1/2-13	.75	12.1	---	52
8	1.31	2.25	4.00	.69	3.13	2	1/2-13	.75	14.3	---	80
10	1.53	2.44	6.25	.81	5.00	4	1/2-13	.88	17.2	1.50	114
12	1.77	2.62	6.25	1.00	5.00	4	1/2-13	.88	19.8	1.50	169

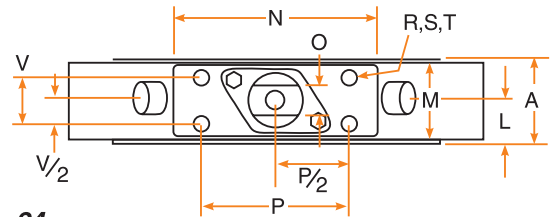

14 - 24 inch valves

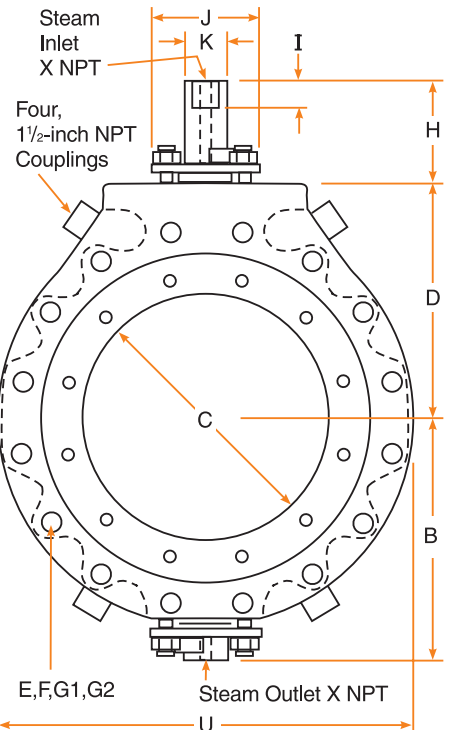

Size	A	B	C	D	E	F	G1	G2	H	I	J	K
14	3.63	12.44	13.04	12.00	18.75	12	1 - 8	1.13	3.50	1.50	3.88	1.50
16	4.00	13.31	14.68	13.25	21.25	16	1 - 8	1.13	3.50	1.50	4.00	1.75
18	4.50	13.94	16.50	14.38	22.75	16	1 1/8 - 8	1.25	3.50	1.50	4.00	1.75
20	5.00	17.44	18.47	15.56	25.00	20	1 1/8 - 8	1.25	5.75	2.00	5.50	2.00
24	6.06	19.25	22.02	17.75	29.50	20	1 1/4 - 8	1.38	5.75	2.50	6.00	2.50

Size	L	M*	N	O	P	R	S	T	U**	V	X	Wt.
14	1.66	2.81	9.50	1.00	8.00	4	5/8-11	Thru	23.00	1.38	1/4-18	235
16	1.83	2.81	9.50	1.12	8.00	4	5/8-11	Thru	25.00	1.38	3/8-18	334
18	2.00	3.00	10.00	1.12	8.00	4	5/8-11	Thru	26.50	1.38	3/8-18	430
20	2.19	3.62	16.00	1.50	13.00	4	1 - 8	2.00	29.00	2.00	1/2-14	551
24	2.62	4.00	16.00	1.75	13.00	4	1 - 8	2.00	33.50	2.00	1/2-14	885

M\* - For valves with carbon steel bodies, M = A.  
 U\*\* - Valves with cast bodies may weigh less.

# High Performance Butterfly Valves For Rail Tank Car Service

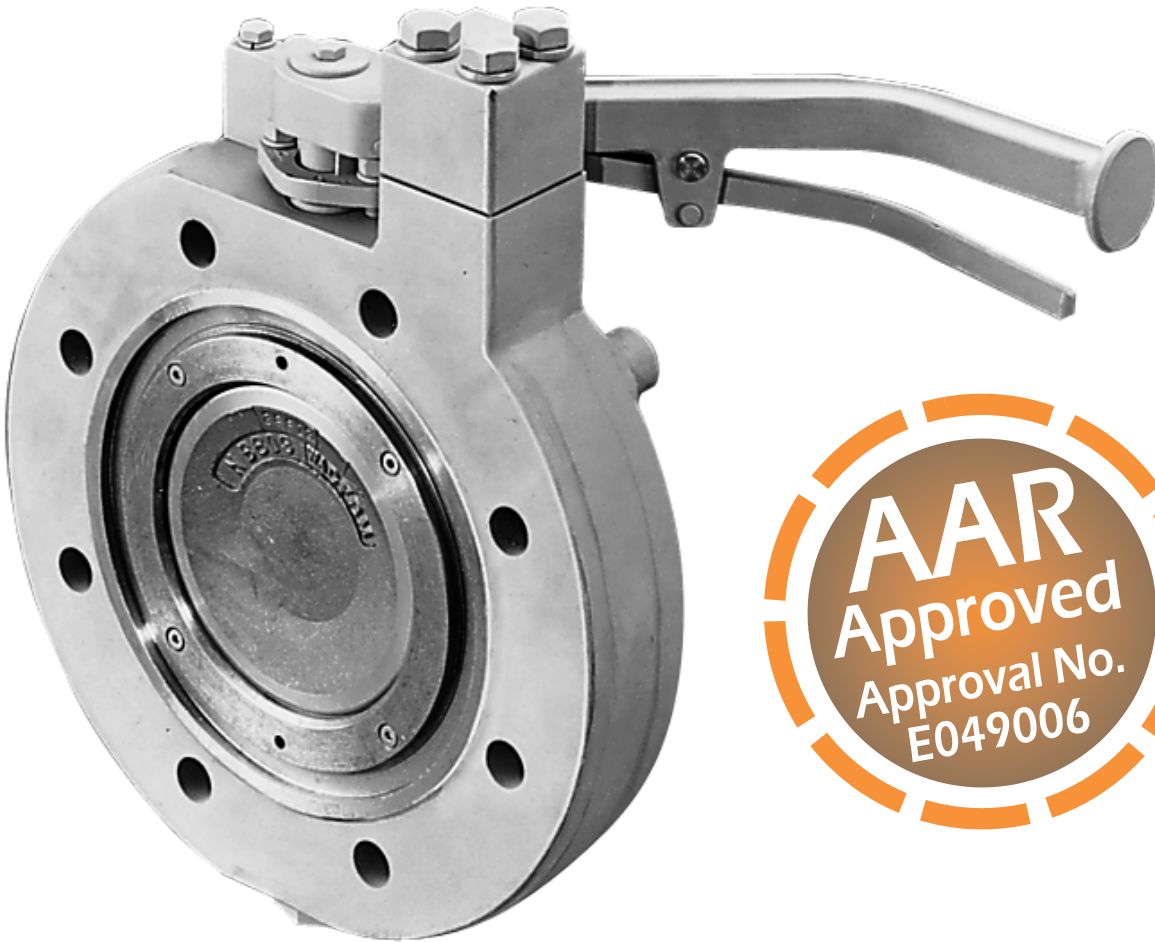

These bottom-mounted, bottom operated valves provide safe, reliable, and economical service in rail tank cars.

## Choose from three styles:

- Fully steam traced - body, shaft, and disc . . . . .STV-6
- Steam jacketed - body only . . . . .SJV-6
- Standard - non-steam traced . . . . .TBFV-6

## Designed specifically for tank car service.

The low profile significantly reduces skidding costs. The patented design is compact and light weight.

Operating costs are reduced because this unique design drains the tank car rapidly and totally.

A spring latch locking mechanism is built into the valve handle. This protects against accidental valve opening and automatically locks in the closed position.

Installation is fast and easy. This valve has proven itself with years of low maintenance extended service life.

## Specifications.

Size . . . . .	.6 inch
Body . . . . .	Carbon or stainless steel
Disc . . . . .	Stainless steel
Shaft . . . . .	.17-4 stainless steel
Seat (standard) . . . . .	Glass-filled PTFE
Seat (optional) . . . . .	PTFE
	UHMWPE
Seat (fire tested) . . . . .	.316SS/PTFE

Other sizes and materials are available upon application.

Dimensions are on the following page.

For more details about unique and patented features request the comprehensive Tufline High Performance Butterfly Valve Catalog.

## Fully Steam Traced Rail Tank Car Valves . . . **STV-6**

Fully Steam Traced STV-6 Valves are designed to facilitate the handling of condensible, solidifying or highly viscous commodities such as sulfur, tar, and pitch.

These valves incorporate steam traced shafts and discs as well as integral steam heating of the valve body perimeter.

This highly efficient heating system prevents buildup on the sealing edge of the disc.

Also prevented are accumulation and solidifying in the shaft bearing area which could cause binding and high operating torques.

## Steam Jacketed Rail Tank Car Valves - Body Jacketed Only . . . **SJV-6**

Integral steam traced jackets facilitate handling moderately viscous commodities.

This includes commodities such as caustic soda, phthalic anhydride, heavy crude vegetable oil and heavy petroleum fuels.

These valves increase unloading efficiency of commodities shipped from warm climates to colder climates.

The SJV has only body steam tracing. There is no disc steam tracing or disc steam connections at the shaft ends.

## Unmatched performance.

These offer unique and patented features found in no other valve. (U.S. Patent Nos. 4,542,763 and 4,688,594.)



Differing Dimensions for the two models:

	A	B
STV	17.84	8.63
SJV	16.59	8.69

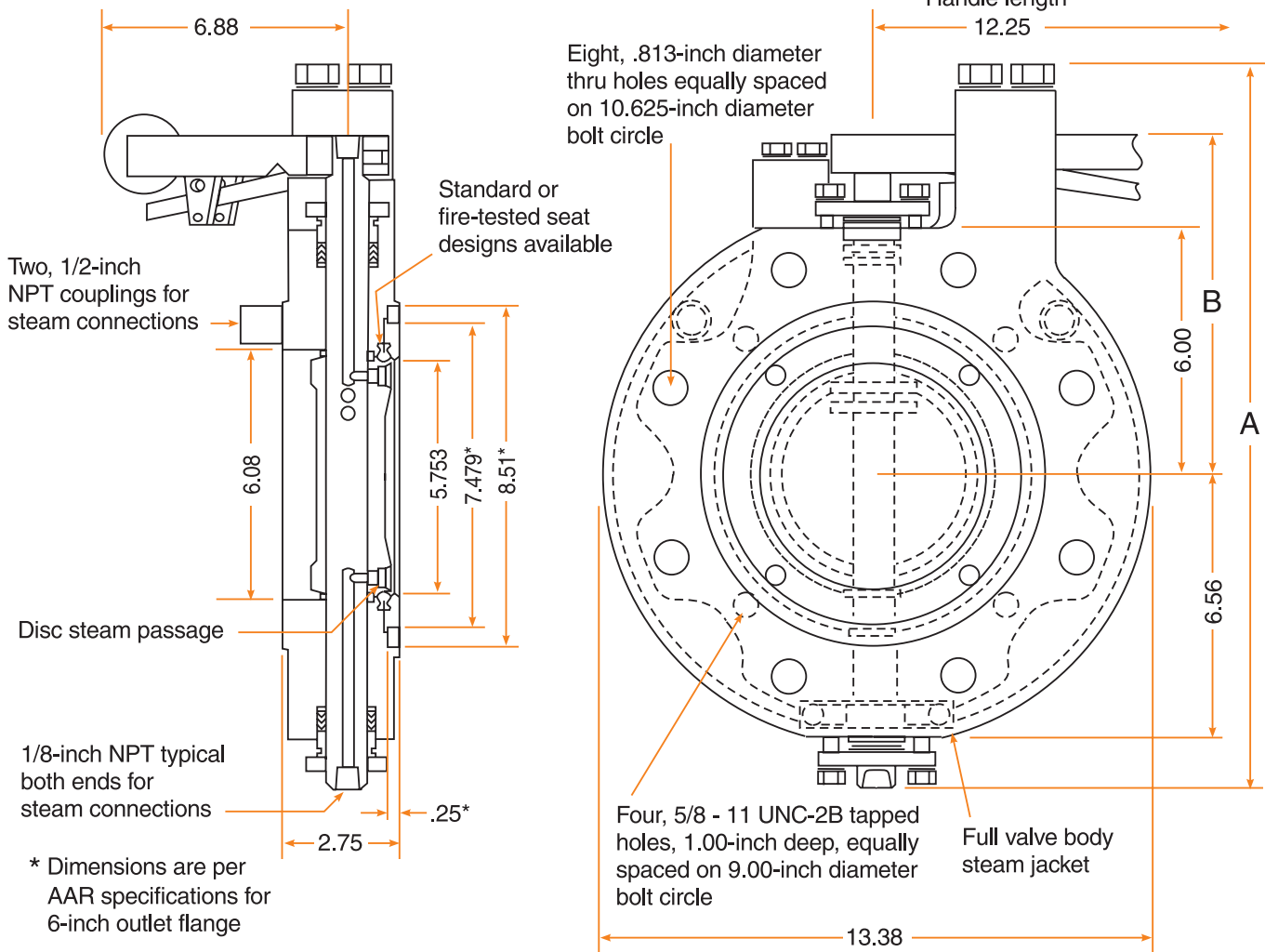

\* Dimensions are per AAR specifications for 6-inch outlet flange

# Non-Steam Traced Rail Tank Car Valves . . . TBFV-6

For non-viscous commodities.

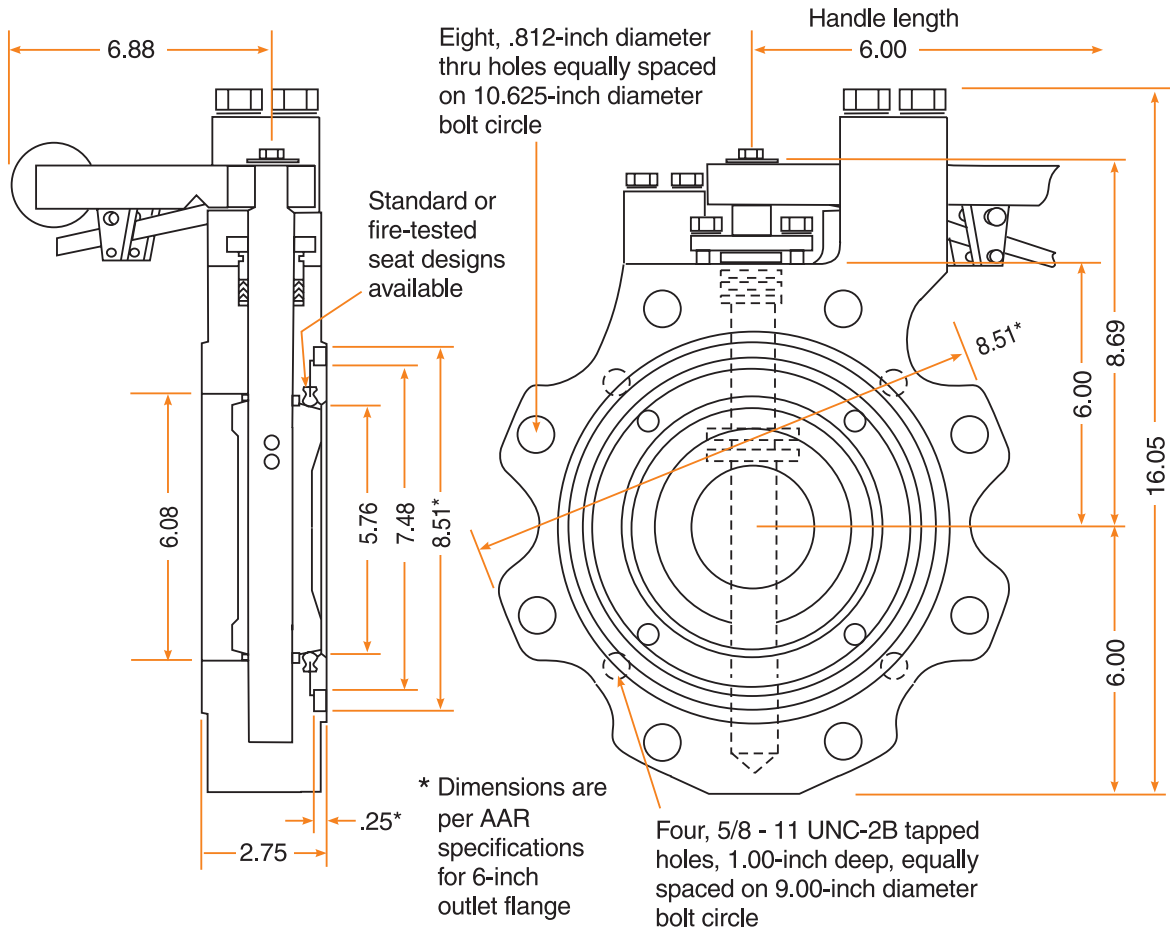

## Pressure / Temperature Ratings

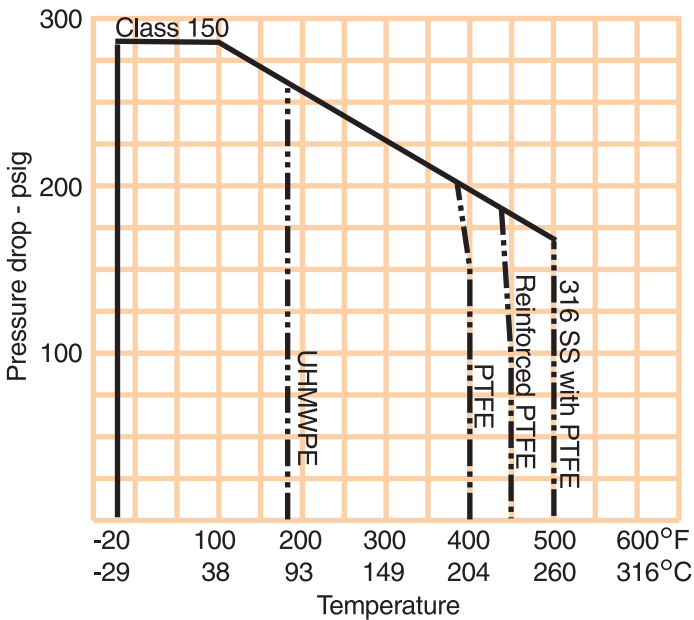

## Steam Traced Rail Tank Car Valves - How To Specify

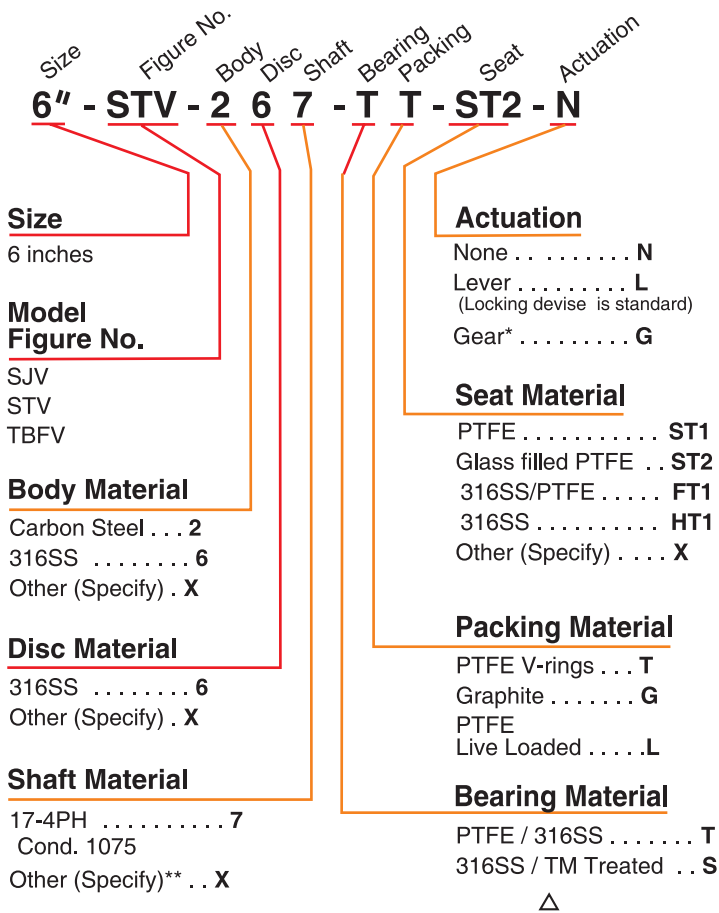

\* Aluminum hear maximum 300°F line temperature. Use DI above 300°F.

\*\* Consult factory for P limitations on shaft materials other than 17-4PH.

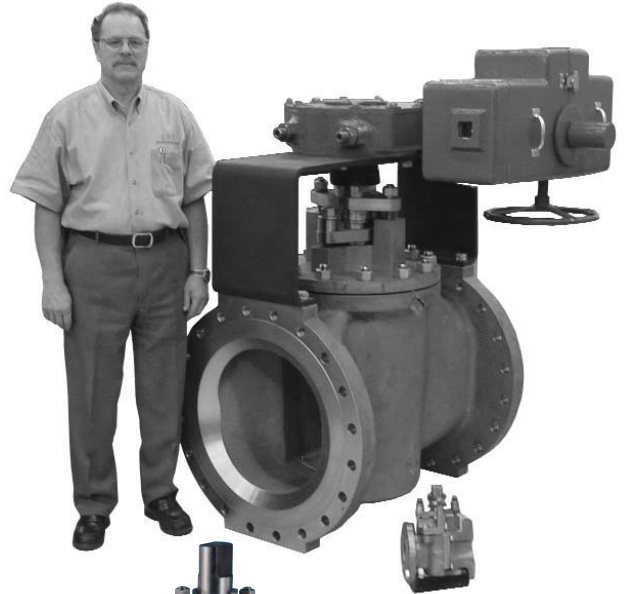

## The Xomox Special Products Group.

The Xomox Special Products Group custom designs, manufactures, and modifies valves.

Tufline Special Products valves are used in unusual, complex, or especially difficult applications.

Processors find that investing in these special valves pays off with greatly extended service life,

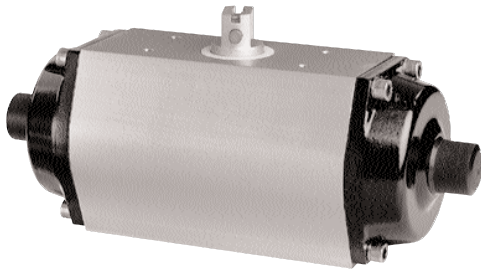

## Xomox XRP™ Actuators

The unique features of Xomox XRP Pneumatic Rack & Pinion Actuators include:

- A balanced pinion which does not require an external retaining clip to prevent the pinion from blowing out.
- Individual single point adjustment for both the CW and CCW directions.
- 98 degrees of total travel on the most popular sizes.
- Vertically aligned air passages allow increased air flow minimizing cycle time.



## Xomox Limit Switches

A wide variety of switching options and other automation accessories are available.



## Matryx® Vane Actuators

Matryx Vane Actuators provide reliable and efficient remote control of any type of rotary operation. They are used for ball, plug, and butterfly valves as well as other mechanisms such as dampers, switches, and safety devices. They are available up to 30,000 in-lbs of torque.



**Xomox Automation & Service Centers** are located throughout the United States. They provide:

- Automated valve packages
- Valve modifications
- Valve repair
- Application assistance
- On-site inventories of valves, actuators, and accessories assure fast turn-around.
- A new-valve factory warranty backs every automated, modified, and repaired valve.



## Matryx Rack & Pinion Actuators

Matryx Rack & Pinion Actuators have a unique suspension system that guides each piston smoothly through its complete stroke, insuring consistent torque output.

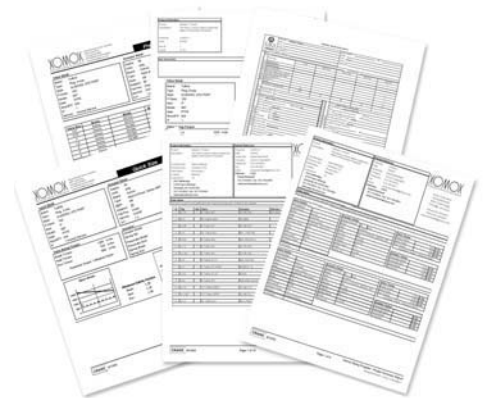

Xomox Sizing Program will help you design a more efficient and economical processing system and assure proper actuator size selection.

# Global Capabilities For Global Customers

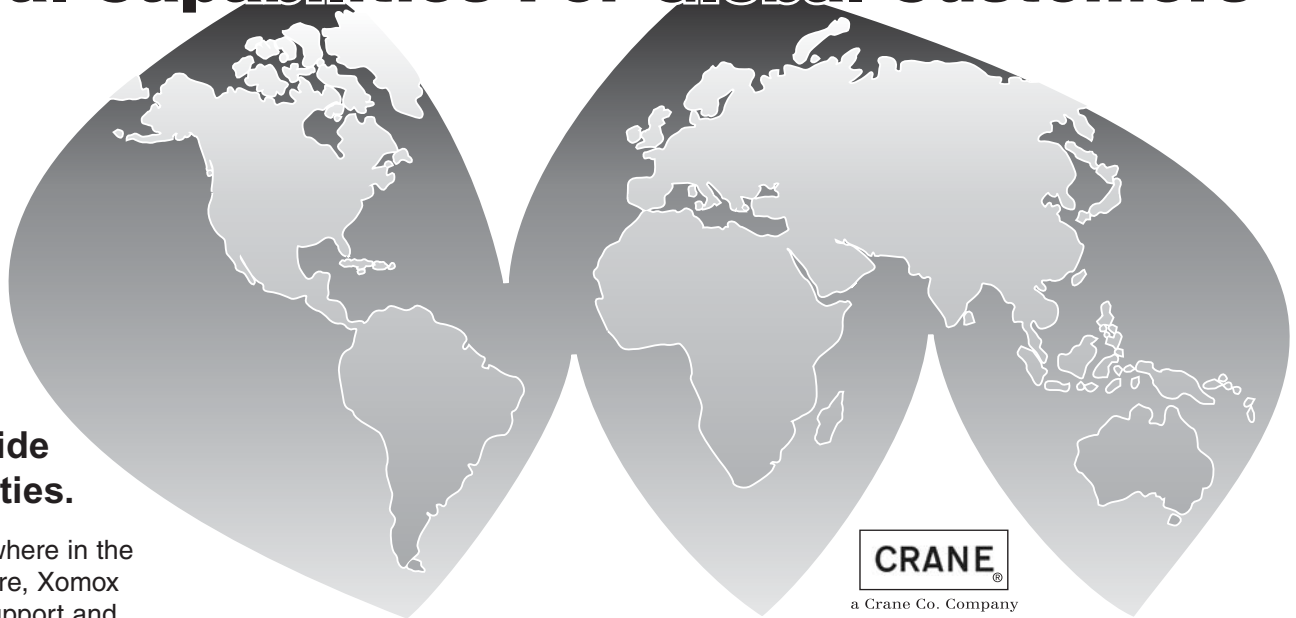

## Worldwide capabilities.

No matter where in the world you are, Xomox technical support and services are available from:

- 16 Manufacturing Facilities
- 18 Service Centers
- 50 Sales Offices
- More than 200 Xomox Authorized Distributors

## Product selection.

Xomox offers the broadest line of process valves, actuators, accessories, and related services including:

- Tuffline® Process Valves
- Saunders® Diaphragm Valves
- Matryx® Rack & Pinion, Vane Actuators
- Xomox XRP™ Actuators

## Product responsibility.

Xomox's concern for product performance extends to the product's period of service. We feel it is important for users to also be aware of their responsibilities. Our products are manufactured and used in numerous applications with a wide variety of service conditions. While general guidelines are often furnished, it obviously is not possible to provide complete and specific performance data for every conceivable service condition. Therefore,

## Global locator.

For a listing of Xomox Manufacturing Facilities, Service Centers, Regional Offices, and Authorized Distributors, visit our web site [www.xomox.com](http://www.xomox.com).

## Xomox literature.

All Xomox catalogs and technical data are available as PDF files at [www.xomox.com](http://www.xomox.com).

## Phone support.

Call your nearest Xomox Sales Office or the Xomox World Headquarters:  
Phone: 513-745-6000  
Fax: 513-745-6093

## Corporate strength.

Xomox is a Crane Co. company. Through the Crane Co. association, Xomox offers even greater global capabilities and breadth of product lines.

## Xomox Corporation

World Headquarters  
4444 Cooper Road  
Cincinnati, Ohio 45242

**XOMOX**<sup>®</sup>  
Process Valves & Actuators

the end user must assume final responsibility for proper evaluation, application and performance of all products. The contents of this document are presented for information purposes only. Every effort has been made to ensure accuracy. This information is not intended to be construed as warranties or guarantees, expressed or implied, nor imply use applicability, for products or services described herein.

We reserve the right to modify or improve the designs and specifica-

tions of such products at any time without notice. As the manufacturer, Xomox sells its products and services pursuant to its standard terms and conditions of sale, including its limited warranty, copies of which are available upon request. Xomox limits its liability specifically to the replacement or repair of defective items, or to a refund for same. Xomox does not accept liability for any incidental or consequential damages.