



DFT[®]

Spring-assisted, Non-slam, Axial Flow, Silent Check Valves

The Check Valve Doctor™

DFT in-line check valves began over 70 years ago with a customer's need for a small metal-seated check valve that could be installed in any position while providing tight shutoff. The Basic-Check® valve was developed to satisfy that need. Over the following decades, other customers' needs led to the development of the ALC®, DLC®, DSV®, Excalibur®, GLC®, PDC®, SCV®, WLC® and Y-Calibur™ styles of axial flow, non-slam silent check valves. Each of these DFT check valves addresses the particular needs of a modern day customer. DFT's objective is to diagnose check valve problems, provide solutions and prevent failures. DFT has learned by listening to customers like you that each industry has special needs that can exceed other check valve designs. We specialize in providing in-line check valves that meet customer requirements as opposed to simply meeting line size. In some cases, minor modifications to our valves have solved customer problems while improving performance and extending service life. The Check Valve Doctor™ continues to grow as a result of satisfying these needs and solving problems, supported by quick response manufacturing and relentless quality control. That's why DFT non-slam check valves are known around the world as the valve to use to prevent or eliminate water hammer problems. Whatever your size, pressure or piping configurations, DFT has a check valve for you. Thank you for considering DFT for your check valve requirements.

Table of Contents

ITEM	PAGE	ITEM	PAGE	ITEM	PAGE
Introduction.....	2	GLC®	20	Nickel-Aluminum Bronze Valves	
Water Hammer.....	3	GLC®-Cast Iron	22	Excalibur®- NAB	38
Features.....	4	PDC®	24	GLC®- NAB	39
Valve Selection Chart.....	5	Sanitary Valves			
Threaded Valves		DSV®	26	Codes and Standards	40
Basic-Check®	6	Wafer Valves			
Restrictor Check.....	8	ALC®	28	NACE.....	41
SCV®	10	FBC®	30	Pressure-Temperature	
SCV-R®	12	WLC®	32	Ratings	42
Vacuum Breaker	14	WLC®-Cast Iron.....	34	Flange Dimensions.....	44
Flanged Valves		In-Line Repairable Valve			
DLC®	16	Y-Calibur™	36	Valve Data Sheet	45
Excalibur®	18			Applications.....	47
				Warranty	47

Hastelloy® is a Registered Trademark of Haynes International Inc.; Inconel® and Monel® are Registered Trademarks of Special Metal Corporation; Rulon® is a Registered Trademark of Dixon Industries Corporation; Teflon® and Viton® are Registered Trademarks of E.I. DuPont Corp.; Tuf-Flex® is a Registered Trademark of Rubber Fab Inc.

ALC®, Basic-Check®, DFT®, DLC®, DSV®, Excalibur®, FBC®, GLC®, PDC®, SCV®, SCV-R®, WLC®, Zelon® are Registered Trademarks of DFT Inc. Y-Calibur™ and The Check Valve Doctor™ are trademarks of DFT Inc.

All other trademarks are the properties of their respective owners and are used for purposes of identification only.

Water Hammer

How DFT Non-Slam Check Valves Prevent Water Hammer

Water hammer is the generation and effect of high-pressure shock waves (transients) in relatively incompressible fluids. Water hammer is caused by the shock waves that are generated when a liquid is stopped abruptly in a pipe by an object such as a valve disc. Symptoms include noise, vibration and hammering pipe sounds which can result in flange breakage, equipment damage, ruptured piping and damage to pipe supports. Whenever incompressible fluids exist in a piping system, the potential exists for water hammer. The risks of water hammer developing are particularly high when the velocity of the fluid is high, when there is a large mass of fluid moving and/or when there are large elevation changes within the piping systems. Since the swing check must rely on gravity and/or fluid flow to help it close, flow reversal must occur before closure begins. When the swing check finally closes, it abruptly stops the flow and causes a pressure surge resulting in shock waves. These shock waves continue until the energy generated from this sudden action dissipates.

Visit www.dft-valves.com to view DFT's check valve animations.

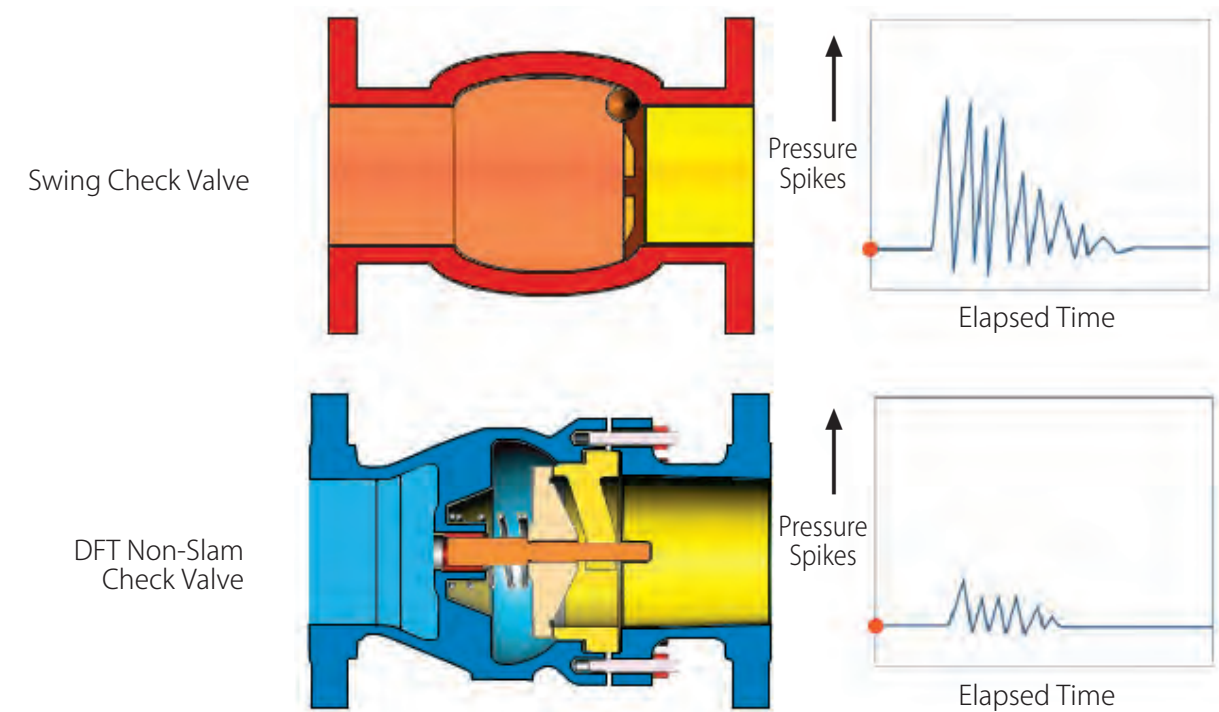

These high-pressure waves act against the piping and the valve, exerting very high forces. This causes severe stress on the metal and vibrations in the system. If the system is not designed to withstand these high transient forces, the pipe could rupture and/or other components in the system, such as pumps and valves, could possibly be damaged. These problems can be eliminated or greatly minimized by installing a spring assisted non-slam check valve. Non-slam check valves do not rely on gravity or fluid flow for their closure. Instead as the forward velocity of the fluid slows, the spring assist on the valve starts to close the disc. Due to the spring assist and the relatively short distance the disc must travel, by the time the forward velocity has decreased to zero, the valve disc has reached the seat and the valve is closed. With reverse flow eliminated, the forces necessary to produce water hammer on both the upstream and downstream sides of the valves are substantially eliminated.

Features

Designed to prevent "Water Hammer."

The spring-assisted, axial flow, in-line, nozzle style, non-slam design featured in all DFT® check valves insures that as the forward flow in a pipeline decreases, the disc begins moving closer to the seat. By the time the flow stops, the disc is closed against the seat preventing flow reversal. This prevents the valve from slamming closed which can cause "Water Hammer" and the resultant noise and damage to piping systems.

Designed to open at approx. 0.5 psi differential pressure and fully open at 1.0 psi differential pressure.

See product tables for specific cracking pressures.

Can be installed in ANY position.

Including vertical with flow up or down. (Special springs may be required)

MSS SP 126-2000 Steel Non-slam Spring-Assisted Center Guided Check Valves Standard

DFT carbon steel, stainless steel and alloy valves meet this standard. (Does not apply to the Basic-Check, Restrictor Check or Vacuum Breaker)

API 6D- Pipeline Valves

Contact DFT for products that meet API 6D.

API 6FD- Fire Test for Check Valves

ASME Class 150 and 300 GLC meet API 6FD. (Line sizes 2-24")

Meet or exceed MSS SP-61 leakage requirements.

Metal-to-metal seating is standard in all DFT non-slam check valves. Cast iron valves meet AWWA seat leakage requirements.

Available with soft seats for bubble-tight shutoff.

Soft seat material selected based on operating temperature and chemical compatibility. See page 42 for available options.

Dual-guided stems.

The stem is guided upstream and downstream to guard against vibrations and insure proper disc seating. (Does not apply to the ALC®, Basic-Check®, DLC®, DSV® (1/2"-2"), Restrictor Check, SCV®, SCV-R® or Vacuum Breaker)

Custom sizing available.

The following DFT check valves can be sized to the appropriate flow conditions: ALC®, Excalibur®, GLC®, WLC®, and Y-Calibur™.

Pulse-damping design.

The DFT Model PDC® is specifically designed for use on the discharge of reciprocating air or gas compressors. The design includes a pulse-damping chamber to protect against premature seat wear due to chattering.

Liquids, gas or steam.

All DFT non-slam check valves provide positive shutoff for applications involving liquids, gas or steam and can be used in most industries including oil and gas, petrochemical, pulp and paper, textiles, food and beverage and commercial construction. Applications include chemical lines, fluid injection, condensate recovery, steam, nitrogen, pump and compressor discharge, chiller and boiler feed systems. See page 47 for additional information.

NACE

Optional body and trim materials to meet the NACE standards MR0103-2003 and MR0175/ISO 15156. See page 41.

Maintenance and Installation guides available for all DFT non-slam check valves.

Valve Selection Chart

	THREADED VALVES					FLANGED VALVES					SANITARY VALVES	WAFER VALVES			IN-LINE REPAIRABLE VALVES	
	Basic-Check®	Restrictor Check	SCV®	SCV-R®	Vacuum Breaker	DLC®	Excalibur®	GLC®	GLC® - CAST IRON	PDC®	DSV®	ALC®	FBC®	WLC®	WLC® - CAST IRON	Y-CALIBUR™
PAGE	6	8	10	12	14	16	18	20	22	24	26	28	30	32	34	36
SIZE	1/4 to 2-1/2	1/4 to 2-1/2	1/2 to 3	1/2 to 2	1 to 4 (OD)	1/2 to 3	2 to 24	1 to 42	2 1/2 to 42	2 to 20	1/2 to 4	2 to 24	1 to 4	1 to 10	2 to 10	4 to 14
ENDS																
NPT	X	X	X(1)	X(1)	X											
SW			X(1)	X(1)												
FLG						X	X	X	X	X						
RTJ							X	X		X				X		
BW							X									X
FLG/BW							X									
Victaulic®							X									
Wafer												X	X	X	X	
Clamped											X					
ASME CLASS																
125									X							X
150						X	X	X		X		X	X	X		
250									X						X	
300						X	X	X		X		X	X	X		
600							X	X		X				X		X
900							X	X		X				X		X
1500							X	X		X				X		X
2500								X						X		X
750 CWP			X	X												
3600 CWP			X													
OTHER	X(2)	X(2)			X(2)			X(3)			X(2)			X(3)		
MATERIALS									BODY/TRIM							
Cast Iron									X(4)						X(4)	
WCB/316 SS*							X	X		X		X		X		X
316 SS/316 SS*	X(5)	X(5)	X	X	X(5)	X	X	X		X	X(5)	X	X	X		
Other Alloys			X	X		X	X	X		X	X			X		X
OPTIONS																
Soft Seat	X	X	X	X	X	X	X	X	X	X		X	X	X	X	X
X-750 Spring	X	X	X(6)	X(6)	X	X(6)	X	X		X		X(6)	X	X		X

Notes: 1. NPT x SW available. 2. CWP RATING BSS, BSA, BSE, BSSV, Restrictor Check: 450 to 2500 CWP depending on size; BSSH6, BSSV6: 450 to 6000 CWP depending on size. BSSH7: 800 to 6000 CWP depending on size. DSV: ASME/ANSI Class 108. 3. API 2000 and 5000 ARE AVAILABLE. Contact DFT for sizes. 4. TRIM MATERIAL: BRONZE OR 316 SS. 5. BODY & SEAT: BSE, BSS, BSSV. Restrictor Check: 303 SS, BSA: 416 SS, BSSH6, BSSH7, BSSV6: 316 SS, DSV: 316L SS. 6. Inconel® X-750 spring is standard. * CF8M is the cast grade of 316 SS.

Visit the literature page at dft-valves.com and use the DFT® VALVE DATA SHEET to make your selection based on your requirements. See page 45.

Basic-Check®

The **DFT® Basic-Check Valve** is a versatile all-purpose, non-slam valve that provides reliable, low-maintenance service for a wide range of liquids, steam and gases at various pressure/temperature combinations. The valve consists of a guard cage, spring, valve disc, retaining ring and seat. It can be combined with pipe fittings such as reducing couplings, drain elbows, etc. to form a complete check valve unit ideally suited for a broad range of pipeline applications or incorporated into machinery for OEM applications. The metal-to-metal sealing area of the Basic-Check valve's disc and seat is precision-lapped, providing very tight shutoff of gas, steam and liquid. If bubble-tight shutoff is required, optional resilient soft seats are available.

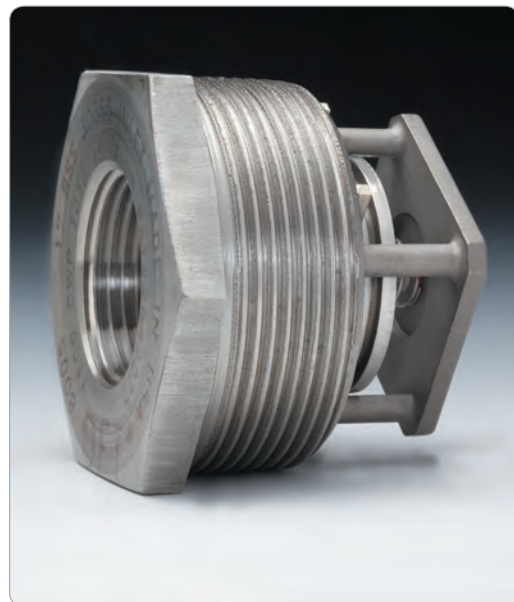

FEATURES:

- 1/4" to 2 1/2" Line size
- 450 to 6000 CWP
- Threaded ends
- Stainless steel construction
- Spring-assisted silent closing
- Horizontal or vertical installation
- Tight shutoff - lapped disc & seat
- Easy maintenance
- Versatile
- Options:
 - Inconel® X-750 spring
 - Soft seat

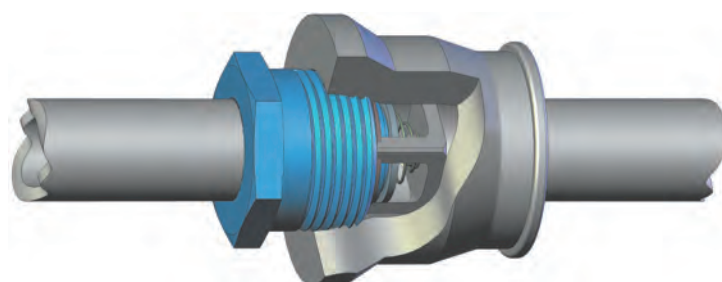

Can be used with reducing coupling

Basic-Check				Cracking Pressure	
A Line Size Inlet (FNPT)	B Outside Thread (MNPT)	Weight	Cv	PSI	Inches of Water
1/4	1	.38	5.8	.60 (1)	16.7
3/8	1	.38	5.8	.60 (1)	16.7
1/2	1	.38	5.8	.60 (1)	16.7
3/4	1 1/2	.88	13.2	.45	12.5
1	2	1.25	23.1	.38	10.5
1 1/4	2 1/2	2.25	36	.20	5.5
1 1/2	3	3.75	57.4	.14	3.9
2	4	7	90	.15	4.3
2 1/2	4	7	90	.15	4.3

*Cracking pressure shown for horizontal installation. Cracking pressure for vertical flow will be slightly different: upward flow, slightly higher; downward flow, slightly less.
Not recommended for use on discharge of reciprocating compressors.

Consult pages 42 and 43 for Pressure/Temperature ratings and soft seat materials.

Basic-Check®

COLD, NON-SHOCK PRESSURE RATING (PSIG) (2)

	1/4", 3/8", 1/2"	3/4"	1"	1 1/4"	1 1/2"	2"	2 1/2"
Basic-Check BSS, BSA, BSE	2500	2000	1500	850	700	450	450
High-Pressure BSSH6	6000	5500	3000	1100	900	450	450
High-Pressure BSSH7	6000	6000	6000	4000	2700	800	800

Sat. Steam Pressure (PSIG) Ref. (3)	Temperature (°F)	Adjusted Rating as Percent of Cold Rating
-3	200	86%
15	250	82%
52	300	78%
232	400	71%
407	450	69%
665	500	66%
1526	600	62%
3075	700	60%

All stainless steel construction is suitable for cryogenic service. For pressure rating at elevated temperatures for standard metal-seated valves, reduce rating per chart above.
Maximum valve temperature rating is limited by soft seat (if any) and spring materials. For ratings of soft seals using some other elastomers, consult DFT.

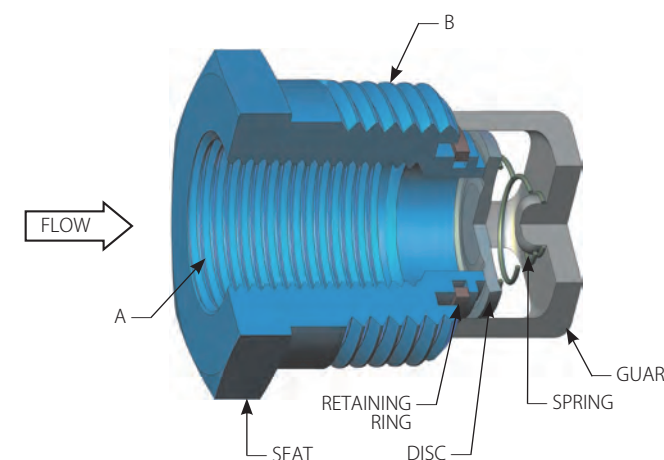

MATERIALS OF CONSTRUCTION

COMPONENT	Basic-Check BSS	Basic-Check BSA	Basic-Check BSE	High Pressure Basic-Check BSSH6	High Pressure Basic-Check BSSH7
Seat	303 SS	416 SS	303 SS	316 SS	316 SS
Disc	316 SS	316 SS	316 SS	316 SS	17-7 SS
Guard	CF8M (4)	CF8M	17-4 SS	CF8M	CF8M
Spring	316 SS	316 SS	Inconel® X-750	316 SS	316 SS
Retaining Ring	316 SS	316 SS	316 SS	316 SS	316 SS

- Notes:**
1. Light spring available: Cracking Pressure = .24 PSI (6.5 inches of water)
 2. Contingent on service ratings of matching pipe and fittings.
 3. Saturated steam pressure is given for reference only; pressure limit of valve is the adjusted rating at the given temperature.
 4. 1/4", 3/8" and 1/2" BSS units have a 303 SS guard.

All dimensions are in inches. Weights are in pounds. For metric measurements, visit www.dft-valves.com. CP: Cracking Pressure (psig)

Restrictor Check

The **DFT® Restrictor Check Valve (RCV)** is a versatile, all-purpose, spring-assisted, non-slam check valve for applications that require higher cracking pressures to open the check valve than those offered by other DFT check valves. Cracking pressures are available from 2 to 40 psi depending on valve size. Like the Basic-Check® valve, the Restrictor Check provides reliable, low maintenance service for a wide range of fluids and gases at various pressure/temperature combinations. The valve consists of a guard cage, spring, valve disc, retaining ring and seat. It can be combined with pipe fittings such as couplings, drain elbows, etc. (not provided by DFT) to form a complete check valve unit ideally suited for a broad range of applications. The RCV should not be considered a substitute for a Pressure Relief Valve.



FEATURES:

- Higher cracking pressures (2 to 40 psi — See chart)
- 1/4" to 2 1/2" Line size
- 450 to 2500 CWP
- Threaded ends
- Stainless steel construction
- Spring-assisted silent closing
- Horizontal or vertical installation
- Tight shutoff - lapped disc & seat
- Easy maintenance
- Versatile
- Options:
 - Soft seat

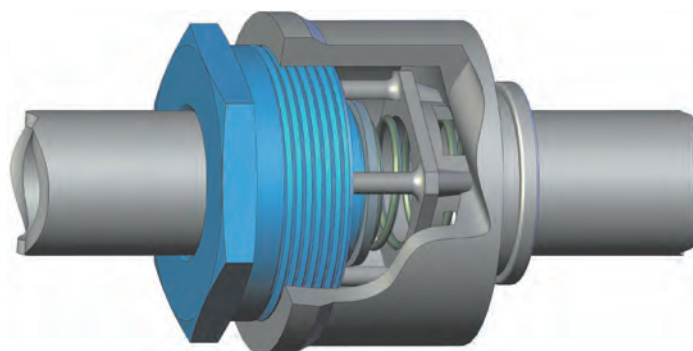

Typical Installation

COLD, NON-SHOCK PRESSURE RATING (1)

Size	1/4", 3/8", 1/2"	3/4"	1"	1 1/4"	1 1/2"	2"	2 1/2"
Rated Working Pressure	2500	2000	1500	850	700	450	450

Consult pages 42 and 43 for Pressure/Temperature ratings and soft seat materials.

Restrictor Check

Sat. Steam Pressure (PSIG) Ref. (2)	Temperature (°F)	Adjusted Rating as Percent of Cold Rating
-3	200	86%
15	250	82%
52	300	78%
232	400	71%
407	450	69%
665	500	66%
1526	600	62%
3075	700	60%

All stainless steel construction is suitable for cryogenic service. For pressure rating at elevated temperatures for standard metal-seated valves, reduce above rating per chart above. Maximum valve temperature rating is limited by soft seal (if any) and spring materials in chart below. For ratings of soft seals using some other elastomers, consult DFT.

MATERIALS OF CONSTRUCTION

Component	Restrictor Check
Seat	303 SS
Disc	316 SS
Guard	CF8M (3)
Spring	302 SS
Retaining Ring	316 SS

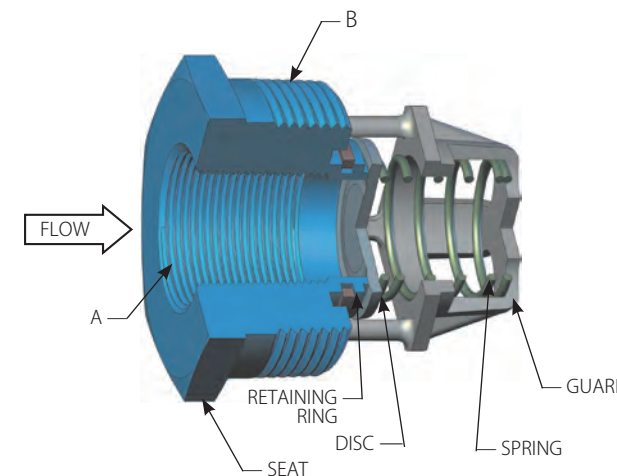

Restrictor Check		
1/4"	A	.25
	B	1
	Weight	.38
	Cv	5.8
3/8"	CP	3.3 to 20.4
	A	.38
	B	1
	Weight	.38
1/2"	Cv	5.8
	CP	3.3 to 20.4
	A	.50
	B	1
3/4"	Weight	.38
	Cv	5.8
	CP	3.3 to 20.4
	A	.75
1"	B	1.50
	Weight	.88
	Cv	13.2
	CP	3.3 to 15.5
1 1/4"	A	1.00
	B	2.00
	Weight	1.25
	Cv	23.1
1 1/2"	CP	4.2 to 40.7
	A	1.25
	B	2.50
	Weight	2.25
2"	Cv	36
	CP	1.8 to 18.8
	A	1.50
	B	3.00
2 1/2"	Weight	3.75
	Cv	57.4
	CP	2.4 to 19.1
	A	2.00
2"	B	4.00
	Weight	7.00
	Cv	90
	CP	1.7 to 9.4
2 1/2"	A	2.50
	B	4.00
	Weight	7.00
	Cv	90
2 1/2"	CP	4.6 to 10.8

Not recommended for use on discharge of reciprocating compressors.

- Notes:**
1. Contingent on service ratings of matching pipe and fittings.
 2. Saturated steam pressure is given for reference only; pressure limit of valve is the adjusted rating at the given temperature.
 3. 1/4", 3/8" and 1/2" BSS units have a 303 SS guard.

All dimensions are in inches. Weights are in pounds. For metric measurements, visit www.dft-valves.com. CP: Cracking Pressure (psig)

The **DFT® Model SCV Check Valve** is a corrosion-resistant, dependable, versatile and economical spring-assisted, non-slam check valve for a wide range of applications. Whether the fluid is liquid, gas or steam, the SCV provides tight shutoff and protects other equipment in the system from water hammer. Its stainless steel construction assures a long service life.



FEATURES:

- 1/2" to 3" Line size
- 750 & 3600 CWP
- NPT & SW ends
- Stainless steel construction
- Inconel® X-750 spring
- Spring-assisted silent closing, non-slam
- Zelon® "O" ring body seal
- Horizontal or vertical installation
- Body-guided disc
- Tight shutoff lapped disc & seat
- Simplified 5-part construction
- Easy maintenance
- Versatile
- Options:
 - 316 SS springs
 - Body seal weld
 - Soft seat
 - Alloy 20 body & seat (ASME 300)
 - Hastelloy® C body & seat (ASME 300)
 - NPT x socket weld ends
 - SCV-R (higher cracking pressure)
 - NACE (Page 41)

MATERIALS OF CONSTRUCTION

COMPONENT	750 CWP	3600 CWP
Body	A351 CF8M	A351 CF8M
Seat (1)	A351 CF8M	A351 CF8M
Disc	A240 316	A240 316
Spring	Inconel® X-750	Inconel® X-750
Body Seal (7)	Standard: Zelon (470°F max.) Option: Body seal weld (700°F max.)	Standard: Zelon (400°F max.)(2) Option: Body seal weld (700°F max.)

Consult pages 42 and 43 for Pressure/Temperature ratings and soft seat materials.

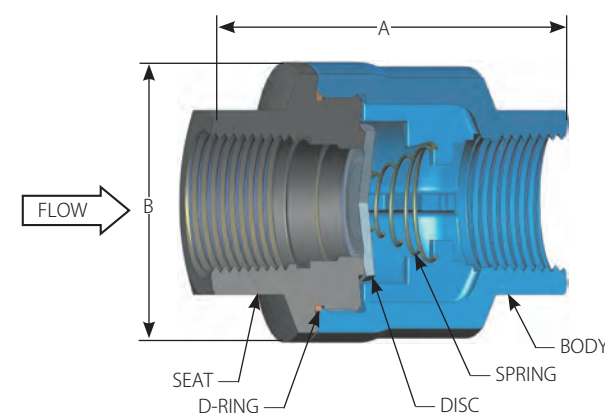
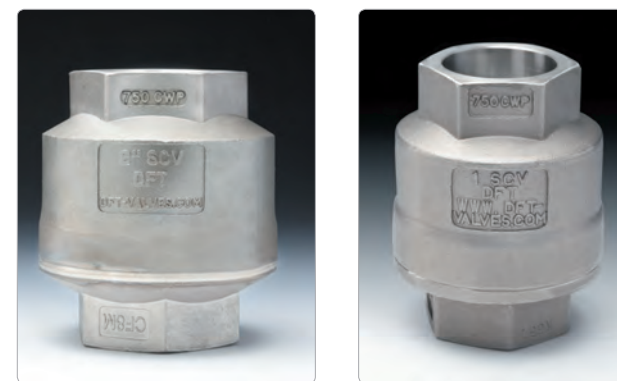

Class	750 CWP/ 500 CWP	3600 CWP	
1/2"	A	2.68	3.16
	B	1.62	1.88
	Weight	1.1	1.5
3/4"	Cv	7	6
	CP	0.29	0.62
	A	3	3
1"	B	2.13	2.33
	Weight	1.5	3
	Cv	13	11
1 1/4"	CP	0.24	0.26
	A	3.32	3.75
	B	2.54	2.75
1 1/2"	Weight	1.9	4.5
	Cv	22	19
	CP	0.36	0.36
2"	A	3.87	6.38
	B	3.06	4.31
	Weight	3.9	14.0
3"	Cv	39	65
	CP	0.28	0.36
	A	4.75	6.75
3"	B	3.44	6.19
	Weight	4.7	18.8
	Cv	54	180
3"	CP	0.24	0.20
	A	5	6.38
	B	4.4	4.31
3"	Weight	7.7	14.0
	Cv	93	65
	CP	0.42	0.36
3"	A	6.75	6.75
	B	6.19	6.19
	Weight	18.8	18.8
3"	Cv	180	180
	CP	0.20	0.20

Not recommended for use on discharge of reciprocating compressors.

PRESSURE TEMPERATURE RATING (PSIG) (3)

Temp. (F°)	A351 CF8M		Alloy 20 (CN7M)	Hastelloy® C (CW-12MW)
	750 CWP	3600 CWP	ASME 300	ASME 300
100	750	3600	600	600
200	645	3095	520	550
250 (4)	610	2945	490	535
300	580	2795	465	520
400 (5)	535	2570	420	490
470 (6)	510			

- Notes:**
1. Soft seats are available for bubble-tight shutoff. See above. Body seal and soft seat material are the same unless otherwise requested.
 2. Buna-N CO₂ resistant "O" ring is available upon request.
 3. ASME B16.34-2013
 4. Maximum temperature for Buna-N.
 5. Maximum temperature for Viton® and Zelon® w/3600 CWP SCV.
 6. Maximum temperature for Zelon® w/750 CWP SCV.
 7. Only Zelon is recommended for steam service.

All dimensions are in inches. Weights are in pounds. For metric measurements, visit www.dft-valves.com. CP: Cracking Pressure (psig)

The **SCV-R Check Valve** is a non-slam spring-assisted check valve designed for applications requiring “higher cracking pressures” than the DFT Model SCV® check valve. The SCV-R check valve is a self-contained check valve that installs directly in a pipeline and contains all of the proven features of the SCV check valve.



FEATURES:

- 1/2" to 2" Line size
- 750 CWP
- NPT & SW ends
- Stainless steel construction
- Inconel® X-750 spring
- Spring-assisted silent closing, non-slam
- Cracking Pressures: 0.8 to 40.8 psig (See chart)
- Zelon® "O" ring body seal
- Horizontal or vertical installation
- Body guided disc
- Tight shutoff lapped disc & seat
- Easy maintenance
- Versatile
- Options:
 - 316 SS springs
 - Body seal weld
 - Soft seat
 - Alloy 20 body & seat (ASME 300)
 - Hastelloy® C body & seat (ASME 300)
 - NPT x socket weld ends
 - Repair kits
 - Field conversion kits

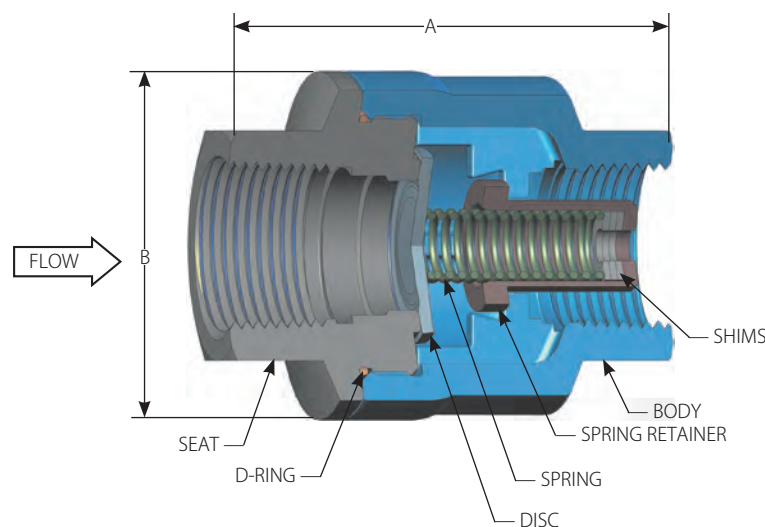

Consult pages 42 and 43 for Pressure/Temperature ratings and soft seat materials.

PRESSURE TEMPERATURE RATING (PSIG) (2)	
Temp. (F°)	750 CWP
100	750
200	645
250	610
300	580
400	535
470	510

MATERIALS OF CONSTRUCTION	
COMPONENT	750 CWP
Body	A351 CF8M
Seat (1)	A351 CF8M
Disc	A240 316
Spring	Inconel® X-750
"O" Ring	Zelon (470°F max.)
Spring Retainer	A479 316
Shims	A240 316

	Class	750 CWP
1/2"	A	2.68
	B	1.62
	Weight	1.1
	Cv	6
	CP	1 to 25
3/4"	A	3
	B	2.13
	Weight	1.5
	CP	0.80 to 20
1"	A	3.32
	B	2.54
	Weight	1.9
	CP	1.2 to 23.5
1 1/4"	A	3.87
	B	3.06
	Weight	3.9
	CP	7.7 to 22
1 1/2"	A	4.75
	B	3.44
	Weight	4.7
	CP	1.4 to 40.8
2"	A	5
	B	4.4
	Weight	7.7
	CP	0.9 to 21.4

Not recommended for use on discharge of reciprocating compressors. Contact DFT for other cracking pressures.

- Notes:**
1. Soft seats are available for bubble tight shutoff. See chart. Body seal and soft seat material are the same unless otherwise requested.
 2. ASME B16.34-2013

All dimensions are in inches. Weights are in pounds. For metric measurements, visit www.dft-valves.com. CP: Cracking Pressure (psig)

Vacuum Breaker

DFT® Vacuum Breakers provide effective protection against collapse of pressure vessels, tanks and rolls. They prevent condensate “back-up” when equipment is shut down or inlet steam is reduced by modulating control valves. In piping systems, DFT Vacuum Breakers are used to break siphons, prevent pipe collapse during transient pressure drops, and to provide addition of air on the downstream side of check valves to dampen water hammer.

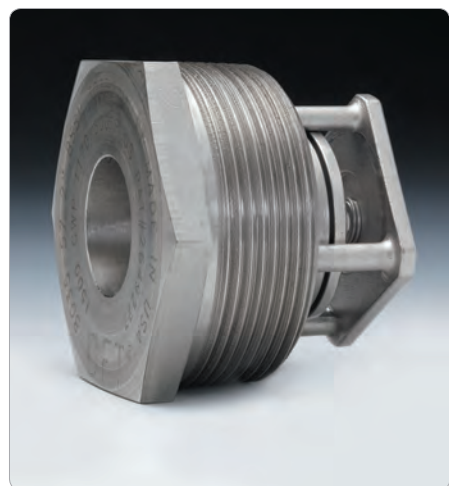

FEATURES:

- 1" to 4" size (Outside diameter)
- 450 to 6000 CWP
- Threaded O.D. (MNPT)
- Unthreaded inlet bore
- Stainless steel construction
- Spring-assisted silent closing
- Horizontal or vertical installation
- Tight shutoff - lapped disc & seat
- Easy maintenance
- Versatile
- Options:
 - Inconel® X-750 spring
 - Soft seat

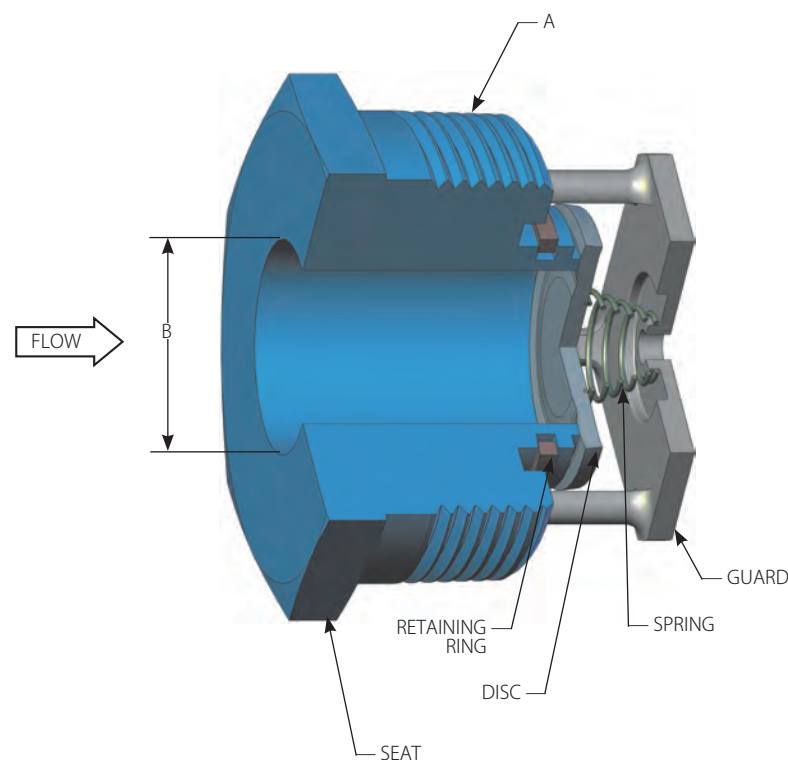

Consult pages 42 and 43 for Pressure/Temperature ratings and soft seat materials.

Vacuum Breaker

Vacuum Breaker				Cracking Pressure	
A Nominal Size (MNPT)	B Unthreaded Inlet Bore	Weight	Cv	PSI	Inches of Water
1	.56	.38	5.8	.60 (1)	16.7
1 1/2	.88	.88	13.2	.45	12.5
2	1.09	1.25	23.1	.38	10.5
2 1/2	1.50	2.25	36	.20	5.5
3	1.72	3.75	57.4	.14	3.9
4	2.22	7.00	90	.15	4.3

*Cracking pressure for vertical flow will be slightly different: upward flow, slightly higher; downward flow, slightly less.

COLD, NON-SHOCK PRESSURE RATING (PSIG) (2)

	1"	1 1/2"	2"	2 1/2"	3"	4"
Vacuum Breaker BSSV	2500	2000	1500	850	700	450
Vacuum Breaker BSSV6	6000	5500	3000	1100	900	450

MATERIALS OF CONSTRUCTION

COMPONENT	Vacuum Breaker BSSV	High Pressure Vacuum Breaker BSSV6
Seat	303 SS	316 SS
Disc	316 SS	316 SS
Guard	CF8M (3)	CF8M
Spring	316 SS	316 SS
Retaining Ring	316 SS	316 SS

Sat. Steam Pressure (PSIG) Ref. (4)	Temperature (°F)	Adjusted Rating as Percent of Cold Rating
-3	200	86%
15	250	82%
52	300	78%
232	400	71%
407	450	69%
665	500	66%
1526	600	62%
3075	700	60%

All stainless steel construction is suitable for cryogenic service. For pressure rating at elevated temperatures for standard metal-seated valves, reduce above rating per chart above. Maximum valve temperature rating is limited by soft seal (if any) and spring materials in chart above.

Notes: 1. Light spring available: Cracking Pressure = .24 PSI (6.5 inches of water)
 2. Contingent on service ratings of matching pipe and fittings.
 3. 1" units have a 303 SS guard.
 4. Saturated steam pressure is given for reference only; pressure limit of valve is the adjusted rating at the given temperature.
 All dimensions are in inches. Weights are in pounds. For metric measurements, visit www.dft-valves.com. CP: Cracking Pressure (psig)

The **DFT® Model DLC Check Valve** is a corrosion-resistant, dependable, versatile and economical spring assisted, non-slam check valve for a wide range of applications. Whether the fluid is liquid, gas or steam, the DLC check valve provides tight shutoff and protects other equipment in the system from water hammer. Its stainless steel construction insures a long service life.



FEATURES:

- ANSI B16.10 Face-to-Face dimensions
- Spring-assisted silent closing, non-slam
- 1/2" to 3" Line size
- ASME Class 150 and 300
- Standard body material:
 - A351 CF8M
- Optional body materials:
 - Alloy 20
 - Hastelloy®
- Stainless steel construction
- Raised face flanged ends
- Inconel® X-750 spring
- Electron beam welded body
- Meets ASME B16.34 - 2013
- Horizontal or vertical installation
- Body-guided disc
- Tight shutoff - lapped disc & seat
- Simplified construction - 4 parts
- Versatile
- Options:
 - 316 SS Springs
 - NACE (Page 41)
 - Soft seat (only Teflon® Encapsulated Viton® available)

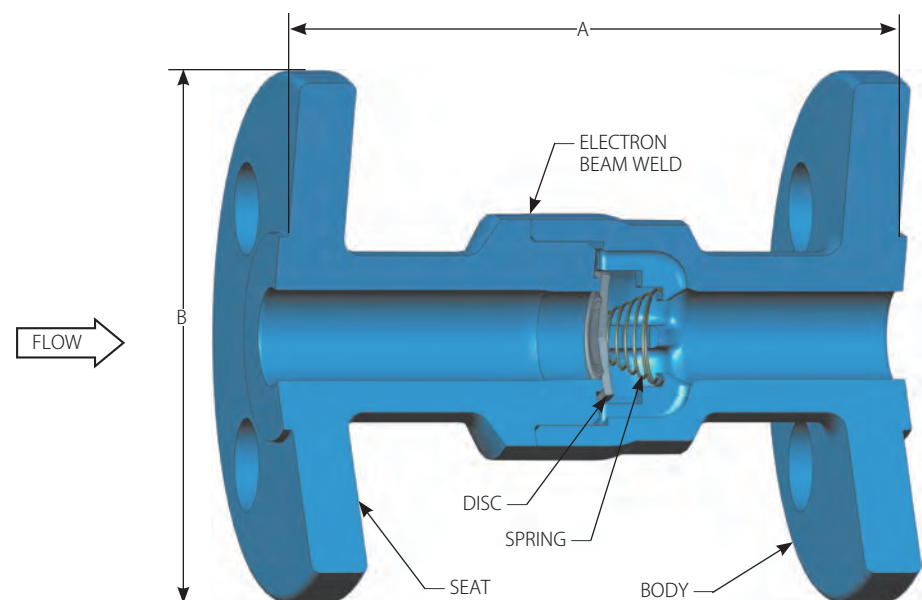

PRESSURE TEMPERATURE RATING (PSIG) (1)

Temp. (°F)	A351 CF8M		Temp. (°F)	Alloy 20 (CN7M)		Hastelloy® C (CW-12MW)	
	ASME 150	ASME 300		ASME 150	ASME 300	ASME 150	ASME 300
-460	275	720	-325	230	600	230	600
100	275	720	100	230	600	230	600
200	235	620	200	200	520	210	550
300	215	560	300	180	465	200	520
400	195	515	400	160	420	190	490
500	170	480	500	150	390	170	465
600	140	450	600	140	360	140	440
700	110	435	700			110	420

MATERIALS OF CONSTRUCTION

COMPONENT	
Body	A351 CF8M
Seat	A351 CF8M
Disc	316 SS
Spring	Inconel® X-750

	Class	150 RF	300 RF
1/2"	A	4.25	6.00
	B	3.50	3.75
	Weight	3.2	4.5
	Cv	7	7
	CP	0.29	0.29
3/4"	A	4.62	7.00
	B	3.88	4.62
	Weight	4.5	7.2
	Cv	13	13
	CP	0.24	0.24
1"	A	5.00	8.50
	B	4.25	4.88
	Weight	6.0	9.9
	Cv	22	22
	CP	0.36	0.36
1 1/2"	A	6.50	9.50
	B	5.00	6.12
	Weight	11.7	18.5
	Cv	54	54
	CP	0.24	0.24
2"	A	8.00	10.50
	B	6.00	6.50
	Weight	19.1	24.3
	Cv	93	93
	CP	0.42	0.23
3"	A	9.50	12.50
	B	7.50	8.25
	Weight	39.2	50.5
	Cv	180	180
	CP	0.20	0.20

Notes: 1. 1. Pressure/temperature ratings in accordance with ASME/ANSI B16.34-2013. All dimensions are in inches. Weights are in pounds. For metric measurements, visit www.dft-valves.com. CP: Cracking Pressure (psig)

Excalibur®

The **DFT® Excalibur Silent Check Valve** is a spring-assisted, center guided, non-slam check valve that provides reliable, low-maintenance service for a wide range of fluids and pressure/temperature combinations. The valve consists of a body, gasket, seat, spring, disc with stem and guide bushing. Excalibur check valves are available in a wide range of sizes and pressure ratings and in a variety of metals to meet most check valve requirements.



FEATURES:

- ASME B16.10 Face-to-Face dimensions
- Spring-assisted silent closing, non-slam
- 2" to 24" Line size
- ASME Class 150 to 1500 (See chart)
- Standard body materials:
 - A216 Grade WCB carbon steel
 - A351 CF8M stainless steel
- Optional body materials:
 - Alloy 20
 - Duplex SS
 - Hastelloy®
 - Inconel® 600
 - Monel®
 - Nickel-Aluminum Bronze (See page 38)
- Standard ends:
 - RF Flanged
- Optional ends (4):
 - Butt weld
 - Flanged x Butt weld
 - RTJ
 - Victaulic®
- Stainless steel trim
- Center-guided
- Dual-guided stem
- Horizontal or vertical installation
- Tight shutoff
- Two-piece body
- Protected spring
- Easy maintenance
- Versatile
- Axial flow
- Nozzle style
- Options:
 - Soft seat
 - Inconel® X-750 Spring
 - Custom sizing low flow
 - Severe service trim
 - Stellite® trim
 - NACE (See page 41)

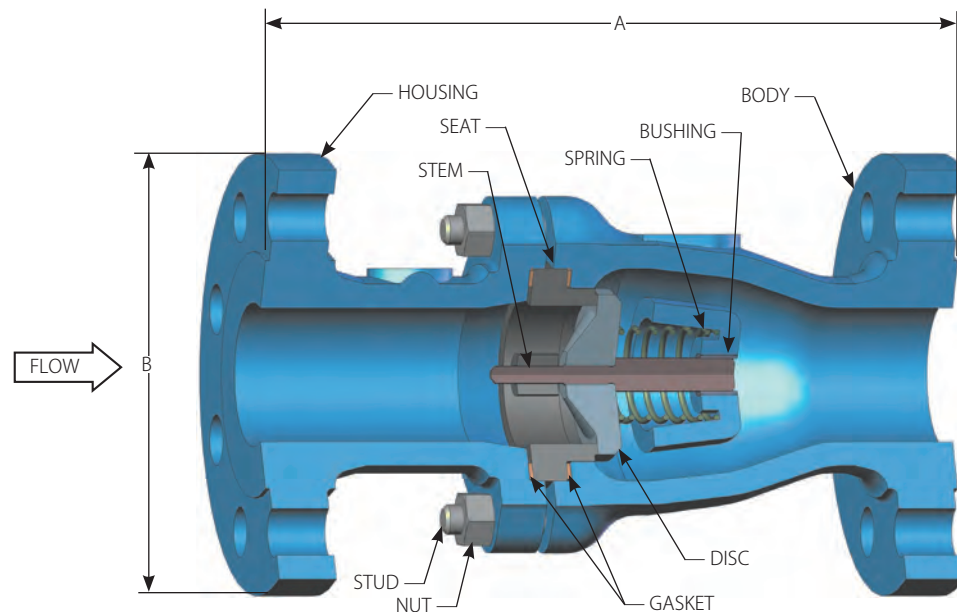

Consult pages 42 and 43 for Pressure/Temperature ratings and soft seat materials.

Excalibur®

MATERIALS OF CONSTRUCTION

COMPONENT	CARBON STEEL BODY	STAINLESS STEEL BODY
Body	A216 Grade WCB	A351 CF8M
Disc/Stem Assembly	A351 CF8M/A479 316	A351 CF8M/A479 316
Seat	A351 CF8M	A351 CF8M
Spring (1)	A313 316	A313 316
Bushing	A479 316	A479 316
Bolting (2)	A193-B7 (Stud) & A194-2h (Nut)	
Gasket (3)	Cl. 150 & 300	Corrugated Flexible Graphite
	Cl. 600+	316 Spiral wound with Flexible Graphite Filler

Class	150 RF	300 RF	600 RF	900 RF	1500 RF	
2"	A	8	10.50	11.50	14.50	14.50
	B	6	6.50	6.50	8.50	8.50
	Weight	22	29	35	81	81
	Cv	65	65	65	51	51
	CP	0.64	0.64	0.64	0.85	0.85
2 1/2"	A	8.50	11.50	*	*	*
	B	7.00	7.50			
	Weight	30	42			
	Cv	105	105			
	CP	0.44	0.37			
3"	A	9.50	12.50	14	15	18.50
	B	7.50	8.25	8.25	9.50	10.50
	Weight	37	52	69	155	158
	Cv	155	155	155	138	109
	CP	0.26	0.26	0.26	0.22	0.28
4"	A	11.50	14	17	18	21.50
	B	9	10	10.75	11.50	12.25
	Weight	64	92	138	176	267
	Cv	265	265	265	242	187
	CP	0.60	0.41	0.51	0.58	0.74
6"	A	14	17.50	22	24	27.75
	B	11	12.50	14	15	15.50
	Weight	114	177	300	780	780
	Cv	685	685	584	512	512
	CP	0.40	0.40	0.73	0.83	0.83
8"	A	19.50	21	26	29	32.75
	B	13.50	15	16.50	18.50	19
	Weight	207	285	481	665	1270
	Cv	1050	1050	985	777	777
	CP	0.58	0.60	0.67	0.54	0.83
10"	A	24.50	24.50	31	33	39
	B	16	17.50	20	21.50	24.31
	Weight	317	456	981	1650	1890
	Cv	1650	1650	1650	1449	1240
	CP	0.52	0.52	0.47	0.58	0.53

Class	150 RF	300 RF	600 RF	900 RF	1500 RF	
12"	A	27.50	28	33	38	*
	B	19	20.50	22	24	
	Weight	457	696	1320	1925	
	Cv	2400	2400	2400	1190	
	CP	0.53	0.53	0.50	0.53	
14"	A	31	33	*	*	*
	B	21	23			
	Weight	642	725			
	Cv	3600	3600			
	CP	0.28	0.28			
16"	A	34	34	*	*	*
	B	23.50	25.50			
	Weight	830	1440			
	Cv	5200	5200			
	CP	0.51	0.51			
18"	A	38.50	38.50	*	*	*
	B	25	28.00			
	Weight	1225	1900			
	Cv	6250	6250			
	CP	0.50	0.50			
20"	A	38.50	40	*	52	*
	B	27.50	30.50		33.75	
	Weight	1500	2375		5220	
	Cv	7850	7850		6240	
	CP	0.50	0.50		.82	
24"	A	51	53	55	*	*
	B	32	36	37		
	Weight	2450	4110	6670		
	Cv	11300	11310	11070		
	CP	0.42	0.42	0.42		

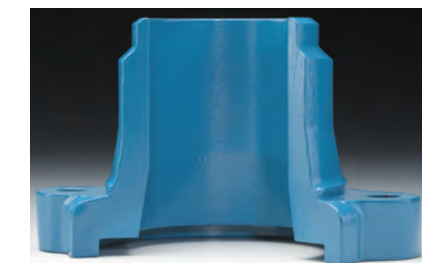

Optional butt weld end

- Notes:**
1. Inconel® X-750 spring is available.
 2. Contact DFT for stainless steel or other bolting materials.
 3. 316 graphite material.
- * Consult DFT for valve availability.

All dimensions are in inches. Weights are in pounds. For metric measurements, visit www.dft-valves.com. CP: Cracking Pressure (psig)

The **DFT® Model GLC Silent Check Valve** is a spring-assisted, center-guided, non-slam, flanged check valve that provides reliable, low-maintenance service for a wide range of fluids and pressure/ temperature combinations. The valve consists of a body, seat, spring, disc with stem, guide bushing and gasket. The DFT GLC check valve has the advantage of minimum pressure loss with silent operation.

FEATURES:

- "Short" Face-to-Face dimensions
- API 6FD Fire Test
 - ASME Class 150 and 300
 - 2" to 24"
- Standard body materials:
 - A216 Grade WCB carbon steel
 - A351 CF8M stainless steel
- Optional body materials:
 - Alloy 20
 - Duplex SS
 - Hastelloy®
 - Monel®
 - Nickel-Aluminum Bronze (See page 39)
- One-piece body
- Spring-assisted silent closing, non-slam
- Center-guided
- Dual-guided stem
- Horizontal or vertical installation
- Protected spring
- Easy maintenance
- Versatile
- ASME Class 150 To 2500 (See chart)
 - 1" to 42" Line size
 - 316 SS trim
 - RF Flanged ends
 - MSS-SP61 seat leakage
- Axial flow
- Nozzle style
- OPTIONS:
 - Inconel® X-750 Spring
 - Soft seat
 - Custom sizing low flow
 - Severe service trim
 - Stellite® trim
 - RTJ Ends (3)
 - NACE (Page 41)

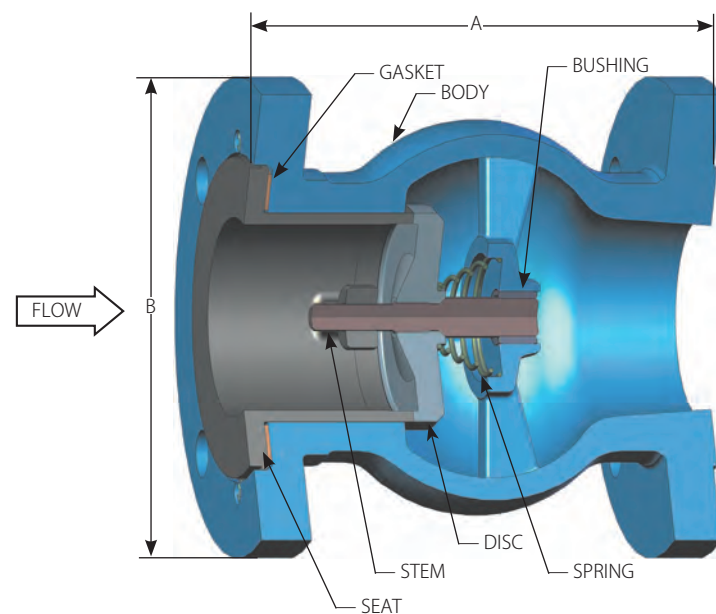
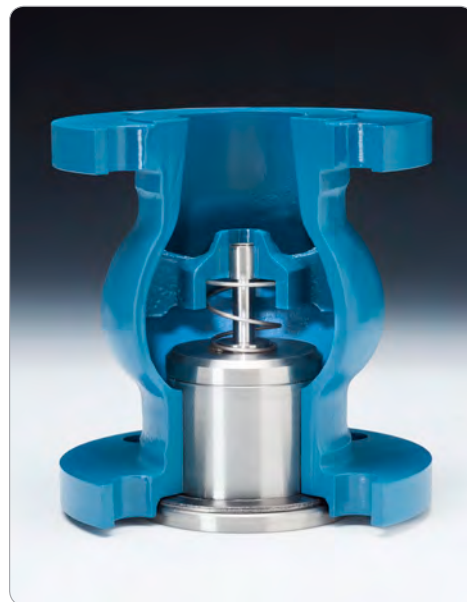

MATERIALS OF CONSTRUCTION

COMPONENT	CARBON STEEL BODY	STAINLESS STEEL BODY
Body	A216 WCB	A351 CF8M
Disc/Stem Assembly	A351 CF8M/A479 316	A351 CF8M/A479 316
Seat	A351 CF8M	A351 CF8M
Spring (1)	A313 316	A313 316
Bushing	A479 316	A479 316
Gasket (2)	CFG/316 SS/Graphite	

Consult pages 42 and 43 for Pressure/Temperature ratings and soft seat materials.

Class	150 RF	300 RF	600 RF	900 RF	1500 RF	2500 RF
1"	A	4.50	4.75	5.25	*	*
	B	4.25	4.88	4.88		
	Weight	7	9	11		
	Cv	17	19	17		
CP	0.85	0.85	0.85			
1 1/2"	A	5.75	6	6.63	7.38	7.38
	B	5	6.13	6.13	7	7
	Weight	13	17	19	30	30
	Cv	35	35	35	26	26
CP	0.29	0.29	0.29	0.64	0.40	
2"	A	6.25	6.50	7.25	8.25	8.25
	B	6	6.50	6.50	8.50	8.50
	Weight	17	23	25	56	56
	Cv	63	63	63	46	46
CP	0.29	0.29	0.29	0.32	0.32	
2 1/2"	A	7.00	7.25	*	9	9
	B	7.00	7.50		9.63	9.63
	Weight	31	41		78	78
	Cv	100	100		81	81
CP	0.18	0.18		0.11	0.11	
3"	A	7.50	7.88	8.63	9.13	9.88
	B	7.50	8.25	8.25	9.50	10.50
	Weight	33	46	57	87	110
	Cv	148	148	125	114	114
CP	0.20	0.20	0.41	0.26	0.52	
4"	A	8.50	9.13	10.13	10.63	11.38
	B	9	10	10.75	11.50	12.25
	Weight	55	71	115	127	164
	Cv	260	267	237	217	192
CP	0.49	0.48	0.54	0.49	0.67	
5"	A	9.50	10.38	*	*	*
	B	10	11			
	Weight	72	89			
	Cv	415	415			
CP	0.28	0.28				
6"	A	10	11	12.38	13	15.13
	B	11	12.50	14	15	15.50
	Weight	93	139	175	264	405
	Cv	620	620	549	549	441
CP	0.41	0.39	0.46	0.46	0.42	

- Notes:**
1. Inconel® X-750 spring is available.
 2. CFG corrugated flexible graphite (Class 150 & 300), 316 SS/Graphite Spiral Wound (Class 600 & up)
 3. Contact DFT for availability.
- * Consult DFT for valve availability.

All dimensions are in inches. Weights are in pounds. For metric measurements, visit www.dft-valves.com. CP: Cracking Pressure (psig)

Class	150 RF	300 RF	600 RF	900 RF	1500 RF	2500 RF
8"	A	12	13	14.63	15.25	17.50
	B	13.5	15	16.50	18.50	19
	Weight	172	232	332	396	670
	Cv	1030	933	933	851	742
CP	0.41	0.45	0.45	0.50	0.55	
10"	A	14	15.38	17.13	17.63	23
	B	16	17.50	20	21.50	23
	Weight	266	335	450	539	1281
	Cv	1630	1704	1620	1499	1231
CP	0.55	0.52	0.35	0.64	0.53	
12"	A	18	19.50	21.25	*	44.50
	B	19	20.50	22		26.50
	Weight	387	550	840		2550
	Cv	2370	2370	2272		1689
CP	0.47	0.49	0.41		0.60	
14"	A	21	23	24	*	*
	B	21	23	23.75		
	Weight	456	724	975		
	Cv	3500	2781	2775		
CP	0.52	0.43	0.43			
16"	A	22.50	24	26	25.81	*
	B	23.50	25.5	27	27.75	
	Weight	700	898	1093	1940	
	Cv	5100	5100	5100	4590	
CP	0.51	0.59	0.59			
18"	A	24	24	*	*	*
	B	25	30.88			
	Weight	753	1255			
	Cv	6400	6400			
CP	0.59	0.59				
20"	A	24	24	35	*	*
	B	27.50	30.50	37		
	Weight	1292	1357	3625		
	Cv	7700	7700	9828		
CP	0.49	0.55	0.59			
24"	A	28	28	29.33	*	*
	B	32	36	37		
	Weight	1571	2420	3470		
	Cv	11100	10510	9850		
CP	0.44	0.46	.57			

GLC®-Cast Iron

The **DFT® Model GLC Silent Check Valve** is a spring-assisted, center-guided, non-slam, flanged check valve that provides reliable, low-maintenance service for a wide range of fluids and pressure/ temperature combinations. The valve consists of a body, seat, spring, disc with stem and guide bushing. Some valves have O-ring or gasket body seals. The DFT GLC check valve has the advantage of minimum pressure loss with silent operation.



FEATURES:

- "Short" Face-to-Face dimensions
- One-piece body
- Spring-assisted silent closing
- Center-guided
- Dual-guided stem
- Horizontal or vertical installation
- Easy maintenance
- Versatile
- ASME Class 125 & 250
 - 2 1/2" to 24" Line size (Cl.125)
 - 2 1/2" to 8" Line size (Cl.250)
 - Cast Iron Body
 - Bronze or 316 SS trim
 - Ends:
- Flat Face Flanged
 - AWWA seat leakage
- Axial flow
- Nozzle style
- Options:
 - Buna-N Soft Seat

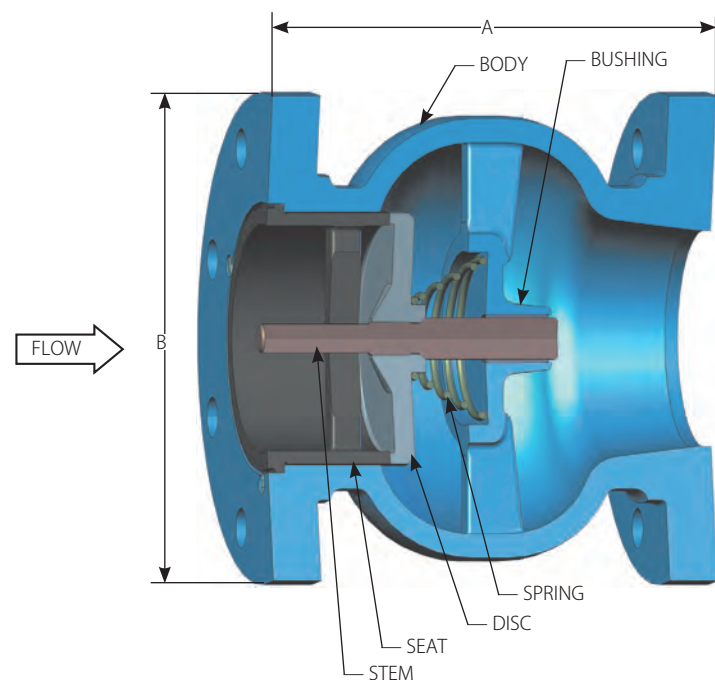

Consult pages 42 and 43 for Pressure/Temperature ratings and soft seat materials.

GLC®-Cast Iron

Class	125 CAST IRON FF	250 CAST IRON FF
2 1/2"	A	5.50
	B	7
	Weight	24
3"	A	6
	B	7.50
	Weight	29
4"	A	7.25
	B	9
	Weight	42
5"	A	8.50
	B	10
	Weight	52
6"	A	9.75
	B	11
	Weight	73
8"	A	12.50
	B	13.50
	Weight	126
10"	A	15.5
	B	16
	Weight	205

Class	125 CAST IRON FF	250 CAST IRON FF
12"	A	14.25
	B	19
	Weight	306
14"	A	15.75
	B	21
	Weight	380
16"	A	17.63
	B	23.50
	Weight	501
18"	A	18.75
	B	25
	Weight	724
20"	A	20.63
	B	27.50
	Weight	890
24"	A	24
	B	32
	Weight	1220

MATERIALS OF CONSTRUCTION

COMPONENT	CAST IRON BODY/BRONZE TRIM	CAST IRON BODY/316 TRIM (1)
Body	A126 Class B Cast Iron	A126 Class B Cast Iron
Disc/Stem Assembly	B584 836 - Bronze	A351 CF8M
Seat (2)	B584 836 - Bronze	A351 CF8M
Spring	A313 T302 SS	A313 T302 SS
Bushing	B584 836 - Bronze	316 SS

MAXIMUM OPERATING TEMPERATURES OF MATERIALS

MATERIALS	SOFT SEAT (2)
TEMP. °F	BUNA-N -70 to 250

PRESSURE TEMPERATURE RATING FOR CAST IRON (PSIG)

	CLASS 125		CLASS 250	
Temp. (°F)	2 1/2" to 12"	14" +	2 1/2" to 12"	14" +
0-150°	200 psig	150 psig	400 psig	300 psig
200° Max (1)	190 psig	135 psig	370 psig	280 psig

Notes: 1. 316 stainless steel trim recommended for temperatures from 180°F to 200°F.
2. Buna-N soft seat available for bubble-tight shutoff.

All dimensions are in inches. Weights are in pounds. For metric measurements, visit www.dft-valves.com. CP: Cracking Pressure (psig)

The **DFT® Model PDC Check Valve** is a silent, non-slam check valve specially designed for use on the discharge side of reciprocating air or gas compressors. It includes a pulse-damping chamber to maintain the disc in the open position during the momentary reductions in flow associated with each cycle of a reciprocating compressor and to protect against premature seat wear.



FEATURES:

- Pulse-damped design
- Modulating "air" or "gas" applications:
 - Discharge of reciprocating air/gas compressors
 - Self sizing accommodates varying flows without chattering
- Meets API 6D
- ASME B16.10 Face-to-Face dimensions
- One-piece body
- Spring-assisted silent closing
- 2" to 20" Line size*
- ASME Class 150 to 1500
- Standard body materials:
 - Carbon steel
 - Stainless steel
- Stainless steel trim
- Stainless steel spring
- Ends:
 - RF Flanged
 - RTJ
- Center guided trim
- Horizontal or vertical installation
- Tight shutoff
- Protected spring
- Easy maintenance
- Versatile
- Axial flow
- Nozzle style
- OPTIONS:
 - Soft seat
 - Inconel® X-750 spring
 - Monel® trim
 - NACE (Page 41)

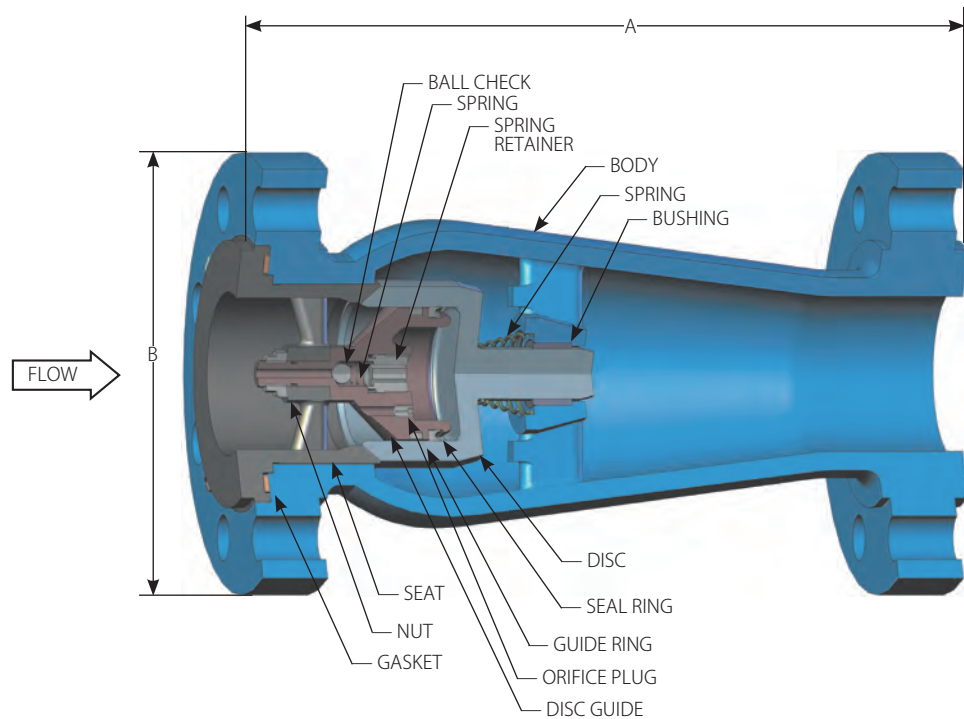

* other sizes available on application

Consult pages 42 and 43 for Pressure/Temperature ratings and soft seat materials.

Class	150 RF	300 RF	600 RF	900 RF	1500 RF	
2"	A	8	10.50	11.50	14.50	14.50
	B	6	6.50	6.50	8.50	8.50
	Weight	20	27	35	65	65
	Cv	62	62	62	55	55
3"	CP	0.41	0.49	0.41	0.35	0.35
	A	9.50	12.50	14	15	18.50
	B	7.50	8.25	8.25	9.50	10.50
	Weight	40	50	58	84	171
4"	Cv	148	148	142	118	118
	CP	0.62	0.62	0.66	0.78	0.78
	A	11.50	14	17	18	*
	B	9	10	10.75	11.50	
6"	Weight	64	82	117	144	
	Cv	255	255	255	224	
	CP	0.68	0.68	0.31	0.82	
	A	14	17.50	22	24	*
8"	B	11	12.50	14	15	
	Weight	94	149	272	322	
	Cv	660	660	660	567	
	CP	0.51	0.51	0.49	0.63	
10"	A	19.50	21	26	29	*
	B	13.50	15	16.50	18.50	
	Weight	158	293	450	575	
	Cv	1005	1005	1005	740	
12"	CP	0.66	0.66	0.42	0.60	
	A	24.50	24.50	31	*	*
	B	16	17.50	20		
	Weight	260	452	740		
1500	Cv	1610	1580	1540		
	CP	0.50	0.38	0.46		
	A	27.50	28	33	38	44.50
	B	19	20.50	22	24	26.50
1500	Weight	445	673	1068	1940	2590
	Cv	2300	2300	2300	1990	1590
	CP	0.29	0.29	0.29	.70	0.70

Contact DFT for additional sizes/pressure classes.

MATERIALS OF CONSTRUCTION

COMPONENT	CARBON STEEL BODY	STAINLESS STEEL BODY
Body	A216 Grade WCB	A351 CF8M
Disc	A351 CF8M	A351 CF8M
Seat	A351 CF8M	A351 CF8M
Spring (1)	A313 316 (450°F max.)	A313 316 (450°F max.)
Spring for ball check	Inconel® X-750	Inconel® X-750
Disc Guide	A479 316	A479 316
Bushing	Rulon® (2)	Rulon® (2)
Seal Ring	Teflon®/Hastelloy® C276	Teflon®/Hastelloy® C276
Spring Retainer - Ball Check	A479 316	A479 316
Guide Ring	Teflon®	Teflon®
Ball Check	440C SS	440C SS
Orifice Plug	A479 316	A479 316
Gasket	Durlon® 9000 for 150 & 300, Stainless/Graphite for 600/900/1500 (500°F Maximum)	Durlon® 9000 for 150 & 300, Stainless/Graphite for 600/900/1500 (500°F Maximum)

PDC temperature rating is limited by the spring material and nonmetallic components.

Notes: 1. Inconel® X-750 spring is available. (500°F maximum)
2. 500°F maximum.

* Consult DFT for valve availability.

All dimensions are in inches. Weights are in pounds. For metric measurements, visit www.dft-valves.com. CP: Cracking Pressure (psig)

The **DSV Check Valve** is a non-slam spring-assisted check valve designed to prevent flow reversal in industries with strict cleanliness codes. To accommodate various piping arrangements, the DSV Check Valve is available as a "Vertical" or "Horizontal" valve. The Horizontal valve is for Horizontal lines requiring a self-draining valve. The "Vertical" design is for "Vertical" installations and "Horizontal" lines when a self-draining valve is not required. The DSV Check Valve, with a 316L stainless steel body and seat, is fastened with a quick release clamp and elastomeric body seal to permit fast and easy access to the internals. The internal surface finish is 25 Ra while the disc and seat are lapped to provide excellent shutoff.



Horizontal

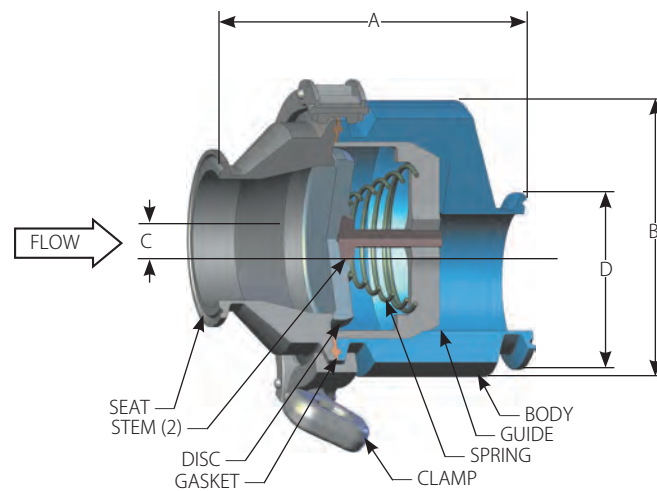

FEATURES:

- Spring-assisted silent closing
- Horizontal or vertical installation
- Sizes 1/2" thru 4"
- 150 CWP, 108 ANSI Pressure Class
- 316L body and seat (A351 CF3M)
- 316 disc, spring and guide assembly
- 25 Ra Internal Surface Finish
- Edge-guided disc: 1/2" thru 2"
- Edge/center-guided disc: 2 1/2", 3", 4"
- Lapped "metal" seat and disc
- Springs:
 - Low cracking pressures
 - .16 psig to .66 psig
 - Conical design
 - Electropolished finish
- Standard body seal:
 - EPDM
- Optional Body Seal:
 - Tuf-Flex® (1)
 - Viton®
- CIP (Clean in Place)
- Clamped ends
- Seat leakage per MSS SP-61
- Options:
 - 15 Ra Electropolished Internal Finish

	Horizontal		Horizontal	
1/2"	A	2.50	A	4.41
	B (Dia.)	1.50	B (Dia.)	3.62
	D (Dia.)	.98	D (Dia.)	2.52
	Weight	1.4	Weight	5.8
	C	.44	C	.50
	Cv	2.4	Cv	47
	CP	.29	CP	.23
3/4"	A	2.50	A	5.56
	B	1.50	B (Dia.)	4.75
	D (Dia.)	.98	D (Dia.)	3.05
	Weight	1.4	Weight	11.2
	C	.31	C	.73
	Cv	7	Cv	69
	CP	.29	CP	.54
1"	A	3.48	A	4.88
	B (Dia.)	3.00	B (Dia.)	4.75
	D (Dia.)	1.98	D (Dia.)	3.58
	Weight	3.7	Weight	9.9
	C	.50	C	.48
	Cv	12	Cv	90
	CP	.36	CP	.54
1 1/2"	A	3.67	A	6.25
	B (Dia.)	3.12	B (Dia.)	7.00
	D (Dia.)	1.98	D (Dia.)	4.68
	Weight	4.0	Weight	22.2
	C	.50	C	.97
	Cv	36	Cv	137
	CP	.28	CP	.50

*Edge/Center Guided Disc

Consult pages 42 and 43 for Pressure/Temperature ratings and soft seat materials.



Vertical

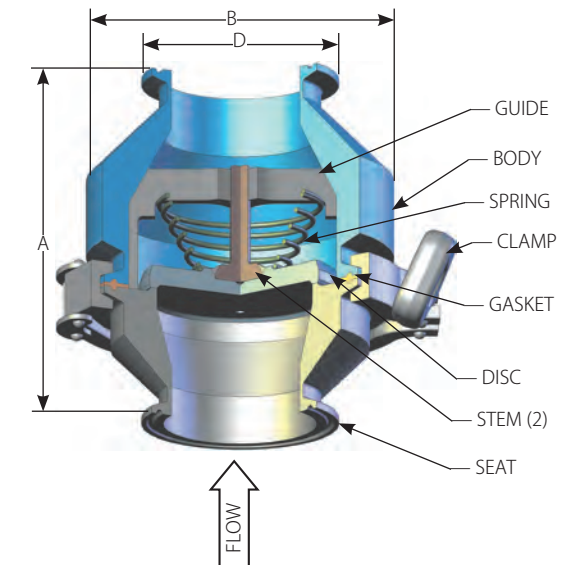

MATERIALS OF CONSTRUCTION

COMPONENT	
Body	A351 CF3M
Seat	A351 CF3M
Disc	316 SS
Spring	316 SS (electropolished)
Guide Assembly	316 SS
Body Seal	EPDM** (-75°F to 300°F)
Clamp	304 SS
Internal Surface Finish	25 Ra

** Other body seal materials available upon request

	Vertical		Vertical	
1/2"	A	2.50	A	4.03
	B (Dia.)	.98	B (Dia.)	3.00
	D (Dia.)	.98	D (Dia.)	2.52
	Weight	1.4	Weight	3.9
	Cv	2.4	Cv	53
	CP Flow Down	.26	CP Flow Down	.16
	CP Flow Up	.33	CP Flow Up	.31
3/4"	A	2.25	A	5.56
	B (Dia.)	.98	B (Dia.)	4.00
	D (Dia.)	.98	D (Dia.)	3.05
	Weight	1.3	Weight	9.9
	Cv	7	Cv	81
	CP Flow Down	.26	CP Flow Down	.42
	CP Flow Up	.33	CP Flow Up	.66
1"	A	2.92	A	4.38
	B (Dia.)	2.00	B (Dia.)	4.00
	D (Dia.)	1.98	D (Dia.)	3.58
	Weight	2.3	Weight	6.1
	Cv	18	Cv	109
	CP Flow Down	.31	CP Flow Down	.42
	CP Flow Up	.41	CP Flow Up	.66
1 1/2"	A	3.29	A	5.50
	B (Dia.)	2.50	B (Dia.)	6.00
	D (Dia.)	1.98	D (Dia.)	4.68
	Weight	2.8	Weight	14.9
	Cv	38	Cv	174
	CP Flow Down	.23	CP Flow Down	.40
	CP Flow Up	.33	CP Flow Up	.60

Notes: 1. PTFE grafted to an EPDM rubber inner core. Good for steam applications.
2. Sizes 2 1/2", 3", 4"

All dimensions are in inches. Weights are in pounds. For metric measurements, visit www.dft-valves.com. CP: Cracking Pressure (psig)

The **ALC Check Valve** is a non-slam spring-assisted, center-guided “wafer” check valve designed to prevent “water hammer” and “reverse” flow. The lightweight compact design fits between mating flanges and meets API 594 Face-to-Face dimensions. The ALC Check Valve is an easy-to-maintain check valve for applications involving liquids, gases or steam. Tapped holes are provided in the body for lifting lugs to assist with installation (10” and larger sizes only).

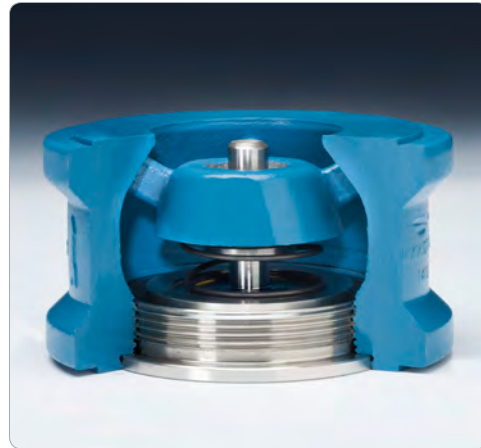

FEATURES:

- API 594 Face-to-Face dimensions
- RF Wafer ends
- Spring-assisted silent closing
- Sizes 2” thru 24”
- Horizontal or vertical installation
- ASME Class 150 and 300
- Standard body materials:
 - A216 Grade WCB carbon steel
 - A351 CF8M stainless steel
- Stainless steel seat, disc & bushing
- Nitronic® 60 stem
- Inconel® X-750 Spring
- Seat Leakage per MSS SP-61
- Tapped holes in body for lifting lugs (10” size and larger)
- Axial flow
- Nozzle style
- Options:
 - 316 SS spring
 - Custom sizing - low flow
 - Soft seat
 - NACE (See page 41)
 - Tapped lug design available (Consult DFT for availability)

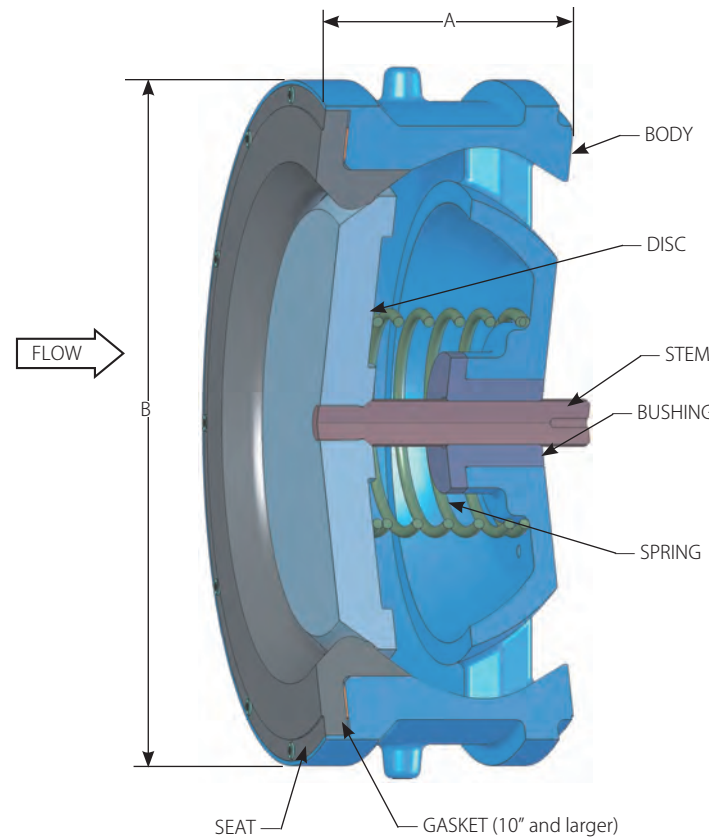

Consult pages 42 and 43 for Pressure/Temperature ratings and soft seat materials.

Class	150 RF	300 RF	Class	150 RF	300 RF	Class	150 RF	300 RF			
2”	A	2.38	2.38	8”	A	5.00	5.00	16”	A	7.50	9.13
	B	4.25	4.25		B	12.00	12.00		B	20.13	21.31
	Weight	5.8	5.8		Weight	68.8	68.8		Weight	315	425
	Cv	120	120		Cv	1310	1310		Cv	3330	4100
	CP	0.65	0.65		CP	0.55	0.55		CP	0.50	0.50
2 1/2”	A	2.62	2.62	10”	A	5.75	5.75	18”	A	8.00	10.38
	B	5.00	5.00		B	14.13	14.13		B	21.50	23.25
	Weight	8.8	8.8		Weight	115	115		Weight	390	618
	Cv	205	205		Cv	1875	1875		Cv	3475	5040
	CP	0.69	0.69		CP	0.53	0.53		CP	0.55	0.55
3”	A	2.88	2.88	12”	A	7.13	7.13	20”	A	8.62	11.50
	B	5.75	5.75		B	16.50	16.50		B	23.75	25.63
	Weight	12.8	12.8		Weight	200	200		Weight	545	760
	Cv	260	260		Cv	2525	2525		Cv	3750	6050
	CP	0.63	0.63		CP	0.53	0.53		CP	0.54	0.57
4”	A	2.88	2.88	14”	A	7.25	8.75	24”	A	8.75	12.50
	B	7.00	7.00		B	17.63	19.00		B	28.13	30.38
	Weight	17.4	17.4		Weight	225	320		Weight	745	1200
	Cv	430	430		Cv	2950	3275		Cv	5150	8325
	CP	0.59	0.59		CP	0.55	0.55		CP	0.52	0.57
6”	A	3.88	3.88		A				A		
	B	9.75	9.75		B				B		
	Weight	38	38		Weight				Weight		
	Cv	825	825		Cv				Cv		
	CP	0.59	0.59		CP				CP		

MATERIALS OF CONSTRUCTION

COMPONENT	CARBON STEEL BODY	STAINLESS STEEL BODY
Body	A216 Grade WCB	A351 CF8M
Disc/Stem Assembly	316 SS/Nitronic® 60	316 SS/Nitronic® 60
Seat	316 SS	316 SS
Spring	Inconel® X-750	Inconel® X-750
Bushing	316 SS (1)	316 SS (1)
Gasket (2)	CFG (3)	CFG (3)

Notes: 1. Teflon® bushing on 14”, 16”, 18”, 20” and 24”.
 2. Gaskets only used on valves 10” and larger.
 3. 316/Graphite material.

All dimensions are in inches. Weights are in pounds. For metric measurements, visit www.dft-valves.com. CP: Cracking Pressure (psig)

The **FBC Check Valve** is a compact, lightweight, insert wafer check valve that easily installs between two flanges. The non-slam, spring-assisted design prevents “water hammer” and “reverse flow”. The FBC Check Valve contains all of the proven features of the Basic-Check® valve developed originally by DFT® and still in use after 60 years. Like the Basic-Check® Valve, the metal-to-metal sealing area of the disc and seat is precision lapped, providing tight shutoff for applications involving liquids, gases or steam. Resilient soft seats are available for applications requiring bubble-tight shutoff.

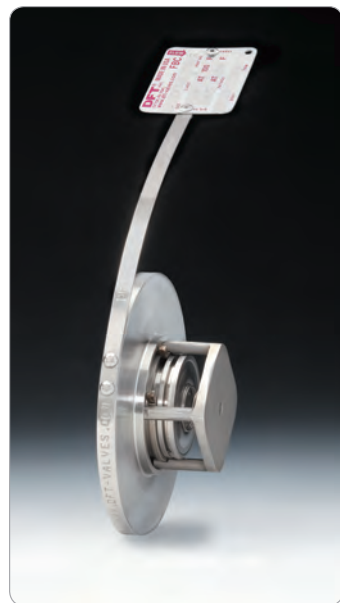

FEATURES:

- Spring-assisted silent closing
- Horizontal or vertical installations
- Sizes 1" through 4"
- ASME/ANSI Class 150 and 300
- Stainless steel seat, disc, guard, retaining ring & spring
- Cracking pressure: 0.6 to 0.15 psi (See chart)
- Temperatures to 450°F for standard valves
- Extended tag for easy identification of the installed valve
- Use in Schedule 40 or Schedule 80 pipe (See chart)
- Meets ASME B16.34-2013 & MSS SP-126
- Flange finish per MSS SP-6
- Seat leakage per MSS SP-61
- Options:
 - Soft seat
 - Inconel® X-750 spring

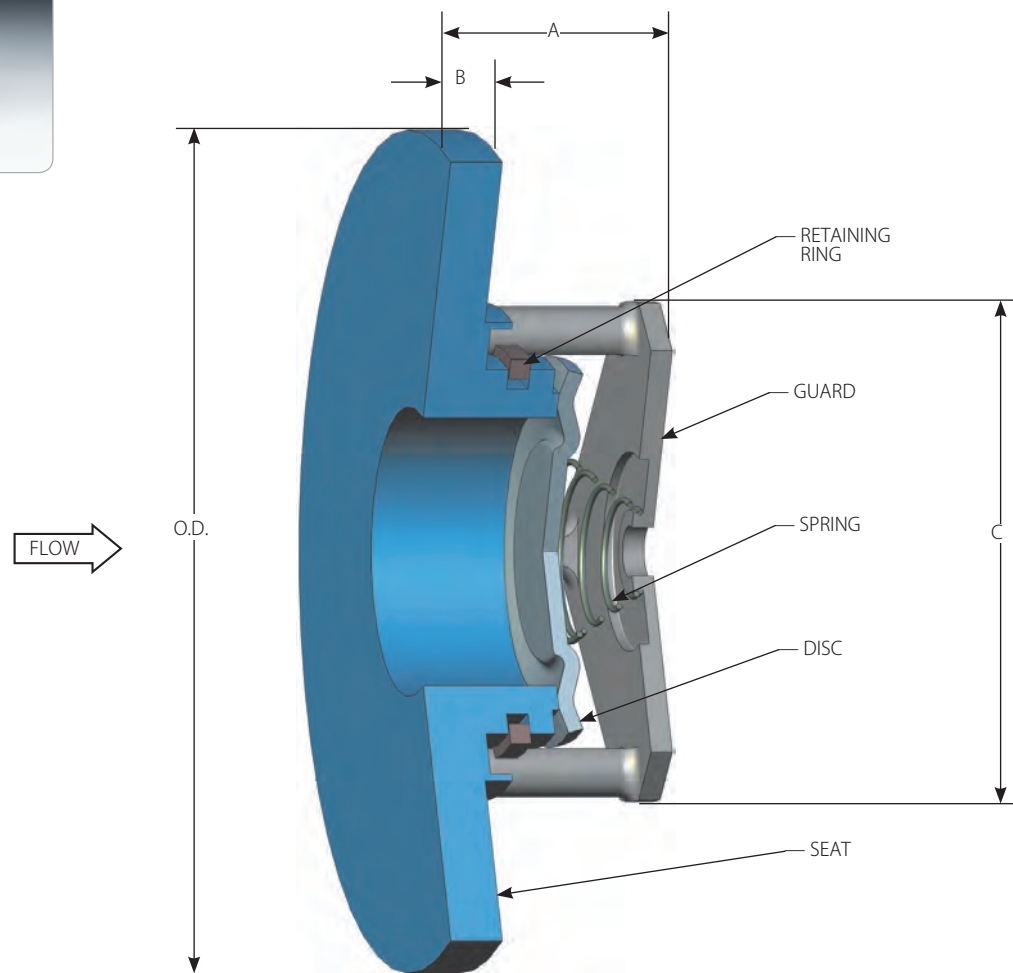

Consult pages 42 and 43 for Pressure/Temperature ratings and soft seat materials.

MATERIALS OF CONSTRUCTION

COMPONENT		
Seat		A479 316
Disc	1" to 3"	316 SS
	4"	17-7 SS
Guard		316 SS
Spring		316 SS
Retaining Ring		316 SS

PRESSURE TEMPERATURE RATING — 316 SS (PSIG) (1)

Temp. (°F)	ASME/ANSI CLASS	
	150	300
100	275	720
200	235	620
250 (2)	225	590
300 (3)	215	560
400 (4)	195	515
450	180	495

Class	150/300	150
1"	A	0.87
	B	0.25
	C	1.03
	O.D.	2.00
	Weight	0.2
	Cv	5.8
1 1/2"	A	1.10
	B	0.25
	C	1.56
	O.D.	2.88
	Weight	0.6
	Cv	13.2
2"	A	1.22
	B	0.25
	C	1.94
	O.D.	3.62
	Weight	0.9
	Cv	23.1
2 1/2"	A	1.31
	B	0.25
	C	2.40
	O.D.	4.12
	Weight	1.2
	Cv	36
3"	A	1.47
	B	0.31
	C	2.97
	O.D.	5.00
	Weight	2.2
	Cv	57.4
4"	A	2.11
	B	0.38
	C	3.70
	O.D.	6.19
	Weight	5.2
	Cv	90
CP	0.15	

Not recommended for use on discharge of reciprocating compressors.

- Notes:**
1. Pressure/temperature ratings in accordance with ASME/ANSI B16.34-2013
 2. Maximum temperature for Buna
 3. Maximum temperature for EPDM
 4. Maximum temperature for Viton®, TFE-encapsulated Viton® and Zelon®
- * Fits schedule 40 pipe only.
** Fits schedule 40 and schedule 80 pipe ID.

All dimensions are in inches. Weights are in pounds. For metric measurements, visit www.dft-valves.com. CP: Cracking Pressure (psig)

The **DFT® Model WLC Wafer Style Check Valve** is a lightweight, spring-assisted, center-guided, non-slam check valve that provides reliable, low-maintenance service for a wide range of fluids and pressure/ temperature combinations. The joint between the seat ring and body is sealed by the flange gasket upon installation preventing any leakage through the joint when the valve is in service.

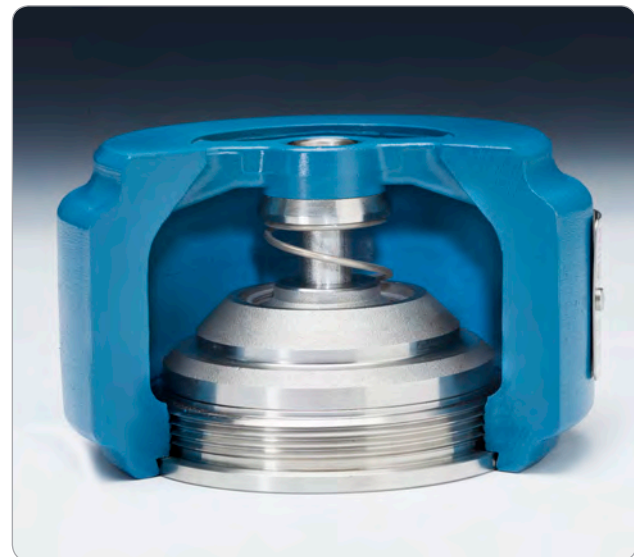

FEATURES:

- Wafer design
- Standard body material:
 - A216 Grade WCB carbon steel
 - A351 CF8M stainless steel
- Optional body materials:
 - Alloy 20
 - Hastelloy®
 - Inconel® 625
 - Duplex SS
 - Titanium
- Lightweight
- Spring-assisted silent closing
- Center-guided/Dual-guided stem
- Horizontal or vertical installation
- Protected spring
- ASME Class 150 to 1500
 - 1" to 10" Line Size
 - 316 SS trim
 - Ends:
 - Wafer RF
 - Wafer RTJ
 - MSS-SP 61 seat leakage
 - MSS 126 Face-to-Face dimension:
 - Class 150 & 300 RF
 - API 594 Face-to-Face dimension:
 - Class 600 RF
 - Class 900 & 1500 RF
- Axial flow
- Nozzle style
- Options:
 - Inconel® X-750 spring
 - Soft seat
 - Custom sizing - low flow
 - Stellite® trim
 - NACE (page 41)
 - Tapped lug design available (Contact DFT for availability)

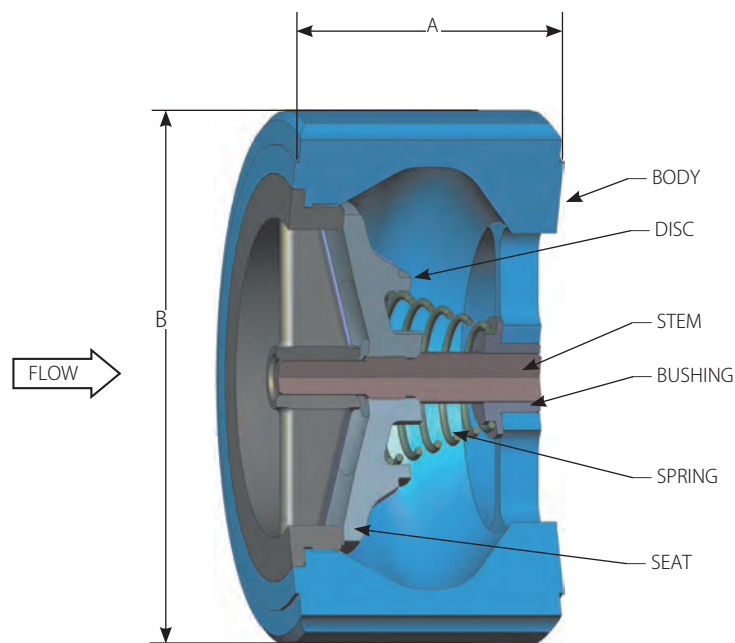

MATERIALS OF CONSTRUCTION

COMPONENT	CARBON STEEL BODY	STAINLESS STEEL BODY
Body	A216 Grade WCB	A351 CF8M
Disc/Stem Assembly	A351 CF8M/A479 316	A351 CF8M/A479 316
Seat	A351 CF8M	A351 CF8M
Spring	A313 316	A313 316
Bushing	A479 316	A479 316

Consult pages 42 and 43 for Pressure/Temperature ratings and soft seat materials.

Class	150 RF	300 RF	600 RF	900 RF	1500 RF	1500 RTJ	2500 RTJ
1"	A	2	2	2.38	2.38	2.38	2.38
	B	2.88	2.88	2.88	3.13	3.13	3.13
	Weight	2	2	2.50	4	4	4.75
	Cv	19	19	19	19	19	19
	CP	0.36	0.36	0.36	0.44	0.44	0.44
1 1/2"	A	2.50	2.50	2.88	2.88	2.88	2.88
	B	3.75	3.75	3.75	3.88	3.88	3.88
	Weight	4	4	6.50	8	8	7
	Cv	36	36	23	23	23	23
	CP	0.17	0.17	0.44	0.54	0.54	0.54
2"	A	2.63	2.63	2.38	2.75	2.75	3.13
	B	4.38	4.38	4.25	5.50	5.50	5.50
	Weight	4	4	5	14	14	14
	Cv	57	57	53	48	48	48
	CP	0.24	0.24	0.26	0.24	0.24	0.24
2 1/2"	A	2.88	2.88		3.63	3.63	3.63
	B	5.13	5.13		6.50	6.50	6.50
	Weight	10	10		20	20	20
	Cv	95	95		70	70	70
	CP	0.37	0.37		0.18	0.18	0.18
3"	A	3.13	3.13	2.88	3.25	3.25	3.38
	B	5.75	5.75	5.75	6.75	6.75	7.50
	Weight	12	12	11	21	21	33
	Cv	140	140	133	113	113	80
	CP	0.19	0.19	0.26	0.19	0.19	0.19
4"	A	4	4	3.13	4	4	4.13
	B	7.13	7.13	7.50	8.13	8.13	8.25
	Weight	20	20	21	38	38	38
	Cv	265	265	234	211	211	211
	CP	0.19	0.19	0.49	0.46	0.46	0.46
5"	A	4.63	4.63		6.25	6.25	
	B	8.50	8.50		11.25	11.25	
	Weight	35	35		100	100	
	Cv	360	360		370	370	
	CP	0.29	0.29		0.58	0.58	
6"	A	5.50	5.50	5.38	6.25	6.25	6.25
	B	9.88	9.88	10.38	11.25	11.25	11.25
	Weight	41	41	68	100	100	100
	Cv	506	506	441	370	370	370
	CP	0.45	0.45	0.66	0.58	0.58	0.58
8"	A	6.50	6.50	6.50	8	8.13	
	B	12.13	12.13	12.63	14.05	13.81	
	Weight	86	86	134	237	244	
	Cv	860	860	780	620	620	
	CP	0.56	0.56	.56	.66	0.66	
10"	A	8.25			9.75	9.75	
	B	17.63			17	17	
	Weight	138			430	430	
	Cv	1355			755	755	
	CP	0.45			0.61	0.61	

All dimensions are in inches. Weights are in pounds. For metric measurements, visit www.dft-valves.com. CP: Cracking Pressure (psig)

WLC®-Cast Iron

The **DFT® Model WLC-Cast Iron Wafer Style Check Valve** is a lightweight, spring-assisted, center-guided, non-slam check valve that provides reliable, low-maintenance service for a wide range of fluids and pressure/temperature combinations. The joint between the seat ring and body is sealed by the flange gasket upon installation, preventing any leakage through the joint when the valve is in service.



FEATURES:

- Wafer design
- Lightweight
- Spring-assisted silent closing
- Center-guided with dual-guided stem
- Horizontal or vertical installation
- Protected spring
- ASME Class 125 & 250
 - 2" to 10" line size
 - Cast iron body
 - Bronze or 316 SS trim
 - Ends: Wafer FF
 - AWWA seat leakage
- Axial flow
- Nozzle style
- Options:
 - Buna-N Soft Seat

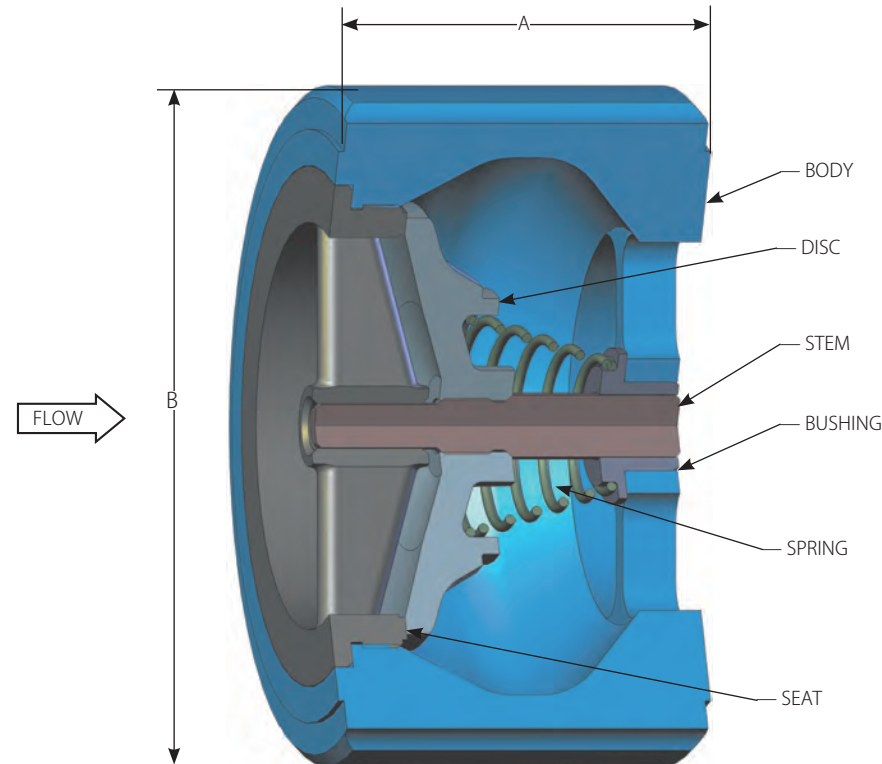

Consult pages 42 and 43 for Pressure/Temperature ratings and soft seat materials.

WLC®-Cast Iron

Class		125 CAST IRON FF	250 CAST IRON FF
2"	A	2.63	2.63
	B	4.25	4.25
	Weight	6	6
2 1/2"	A	66	66
	B	2.88	2.88
	Weight	7	7
3"	A	88	88
	B	3.13	3.13
	Weight	12	12
4"	A	5.75	5.75
	B	7	7
	Weight	18	18
5"	A	228	228
	B	4.75	4.75
	Weight	27	27
6"	A	350	350
	B	5.50	5.50
	Weight	42	42
8"	A	520	520
	B	6.50	6.50
	Weight	85	86
10"	A	900	900
	B	8.25	8.25
	Weight	129	137
	Cv	1450	1450

PRESSURE TEMPERATURE RATING FOR CAST IRON (PSIG)

Temp. (°F)	CLASS 125	CLASS 250
0-150°	200 psig	400 psig
200° Max (1)	190 psig	370 psig

MATERIALS OF CONSTRUCTION

COMPONENT	CAST IRON BODY/BRONZE TRIM	CAST IRON BODY/316 TRIM (1)
Body	A126 Class B Cast Iron	A126 Class B Cast Iron
Disc/Stem Assembly	B584 836 - Bronze	A351 CF8M
Seat (2)	B584 836 - Bronze	A351 CF8M
Spring	A313 T302 SS	A313 T302 SS
Bushing	B584 836 - Bronze	316 SS

Notes: 1. 316 stainless steel trim recommended for temperatures from 180°F to 200°F.
2. Buna-N soft seat available for bubble-tight shutoff.

All dimensions are in inches. Weights are in pounds. For metric measurements, visit www.dft-valves.com. CP: Cracking Pressure (psig)

Y-Calibur™

The **DFT® Y-Calibur™ Silent Check Valve** is an in line repairable, spring-assisted, center guided, non-slam check valve that provides reliable, low-maintenance service for a wide range of fluids and pressure/temperature combinations. The valve consists of a body, bonnet, gasket, seat, spring, disc with stem and guide bushing. Y-Calibur check valves are available in a wide range of sizes and pressure ratings and in a variety of materials to meet most check valve requirements.



FEATURES:

- ASME B16.10 Face-to-Face dimensions
- Spring-assisted silent closing, non-slam
- 4" to 14" Line size *
- ASME Class 600 to 2500 (See chart)
- Standard body materials:
 - A216 WCB carbon steel
 - A351 CF8M stainless steel
- Optional body materials:
 - Duplex SS
 - Hastelloy®
 - Inconel® 600
 - Monel®
- Standard ends:
 - Butt weld
- Stainless steel trim
 - Other materials available
- Center-guided
- Dual-guided stem & disc
- Horizontal or vertical installation
- Tight shutoff
- Protected spring
- Fully repairable in-line
- Versatile
- Axial flow/non-slam design
- Options:
 - Inconel® X-750 Spring
 - Custom sizing low flow
 - Severe service trim
 - Stellite® trim
 - NACE (See page 41)

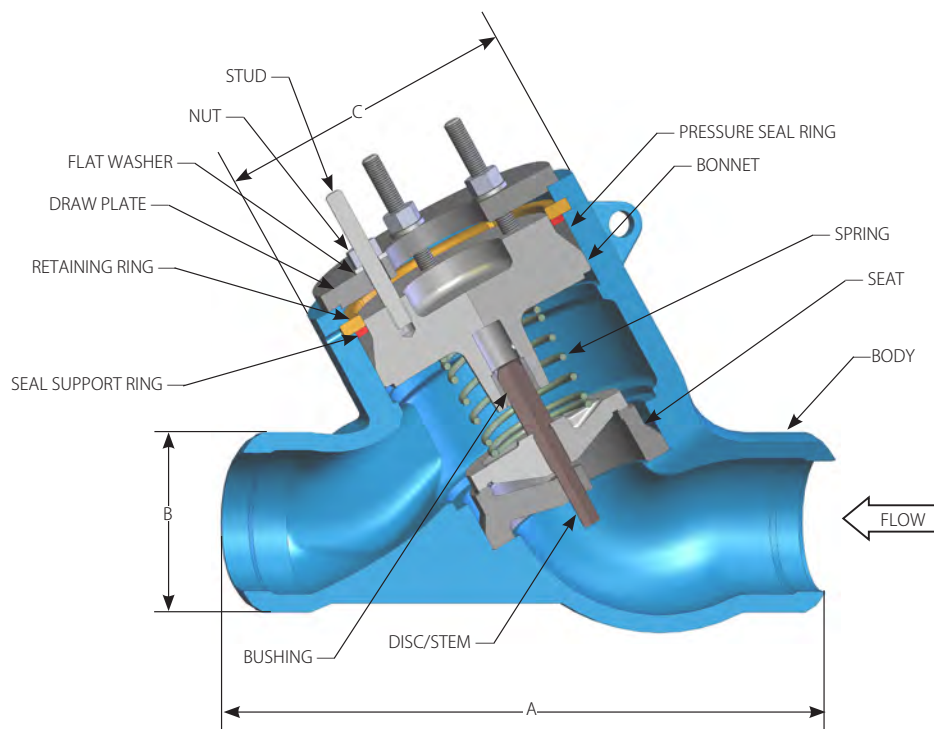

* other sizes available on application

Consult pages 42 and 43 for Pressure/Temperature ratings and soft seat materials.

Y-Calibur™

MATERIALS OF CONSTRUCTION

COMPONENT	CARBON STEEL BODY	STAINLESS STEEL BODY
Body and Bonnet	A216 WCB	A351 CF8M
Disc/Stem Assembly	A351 CF8M/A479 316	A351 CF8M/A479 316
Seat	A351 CF8M	A351 CF8M
Spring (1)	A313 316	A313 316
Bushing	A479 316	A479 316
Bolting (2)	A193-B7 (Stud) & A194-2H (Nut)	
Seal	Graphite	

Class	600	900	1500	2500	
4"	A	17	18	21.5	
	B	3.82	3.43	3.15	
	C	8.38	8.88	10.00	
	Weight	103	150	211	
6"	Cv	265	265	265	
	A	22	24	27.8	36
	B	5.76	5.18	4.89	4.90
	C	11.63	12.25	13.75	15
8"	Weight	250	312	479	965
	Cv	685	685	685	617
	A	26	29	32.8	40.25
	B	7.62	6.81	6.87	6.90
10"	C	14.50	15.38	15.25	21
	Weight	461	597	903	1995
	Cv	1050	1050	1050	945
	A	31	33	39	50
12"	B	9.56	8.75	8.5	8.75
	C	18.50	19.63	21.88	27
	Weight	801	1084	1886	3845
	Cv	1650	1650	1650	1485
12"	A	33	38	44.5	
	B	11.37	10.75	10.12	
	C	22.38	22.38	24.00	
	Weight	1058	1440	2625	
	Cv	2400	2400	2400	

Contact DFT for additional sizes/pressure classes.

- Notes:**
1. Inconel® X-750 spring is available.
 2. Contact DFT for stainless steel or other bolting materials.

All dimensions are in inches. Weights are in pounds. For metric measurements, visit www.dft-valves.com. CP: Cracking Pressure (psig)

Excalibur® - NAB

The **DFT® Excalibur® NAB (Nickel-Aluminum Bronze) Silent Check Valve** is a spring-assisted, nozzle style, non-slam check valve that is designed to withstand the harsh environments of salt and brackish water applications where corrosion resistance and marine life deterrents are a must. DFT's center guided check valves provide reliable, low-maintenance service and solve the problems associated with water hammer and severe applications and environments.

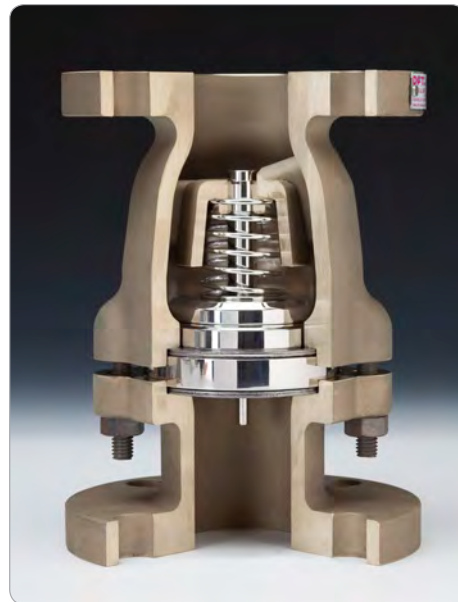

FEATURES:

- ASME B16.10 Face-to-Face dimensions
 - Spring-assisted silent closing, non-slam
 - 2" to 24" Line size
 - ASME Class 150 & 300
 - Standard body materials:
 - Nickel-Aluminum Bronze
 - Standard ends:
 - Flat face flanged
 - Optional ends:
 - Butt weld
 - Flanged x Butt weld
 - Raised face
 - Center-guided
 - Dual-guided stem
 - Horizontal or vertical installation
 - Tight shutoff
 - Two-piece body
 - Protected spring
 - Easy maintenance
 - Versatile
- Axial flow
 - Nozzle style
 - Options:
 - Soft seat
 - Inconel® X-750 Spring
 - Custom sizing low flow
 - Severe service trim
 - Stellite® trim
 - Trim Options:
 - Nickel-Aluminum Bronze
 - Monel®
 - Stainless Steel
 - Duplex SS

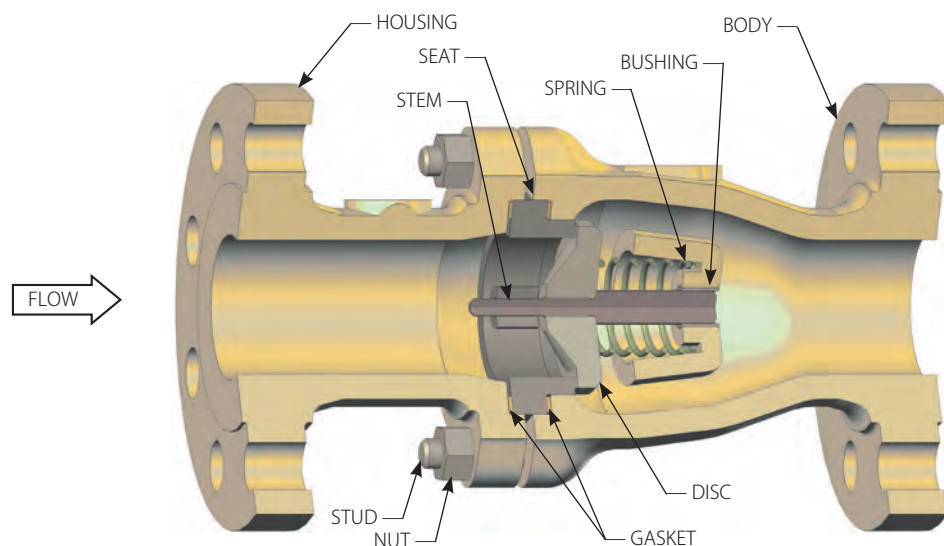

Consult pages 42 and 43 for Pressure/Temperature ratings and soft seat materials.

GLC® - NAB

The **DFT® GLC® NAB (Nickel-Aluminum Bronze) Silent Check Valve** is a spring-assisted, nozzle style, non-slam check valve that is designed to withstand the harsh environments of salt and brackish water applications where corrosion resistance and marine life deterrents are a must. DFT's center guided check valves provide reliable, low-maintenance service and solve the problems associated with water hammer and severe applications and environments.



FEATURES:

- "Short" Face-to-Face dimensions
 - Standard body materials:
 - Nickel-Aluminum Bronze
 - One-piece body
 - Spring-assisted silent closing, non-slam
 - Center-guided
 - Dual-guided stem
 - Horizontal or vertical installation
 - Protected spring
 - Easy maintenance
 - Versatile
 - ASME Class 150 & 300
 - 1" to 24" Line size
 - Flat face flanged ends
 - MSS-SP61 seat leakage
 - Axial flow
 - Nozzle style
- Options:
 - Inconel® X-750 Spring
 - Soft seat
 - Custom sizing low flow
 - Severe service trim
 - Stellite® trim
 - Trim Options:
 - Nickel-Aluminum Bronze
 - Monel®
 - Stainless Steel
 - Duplex SS

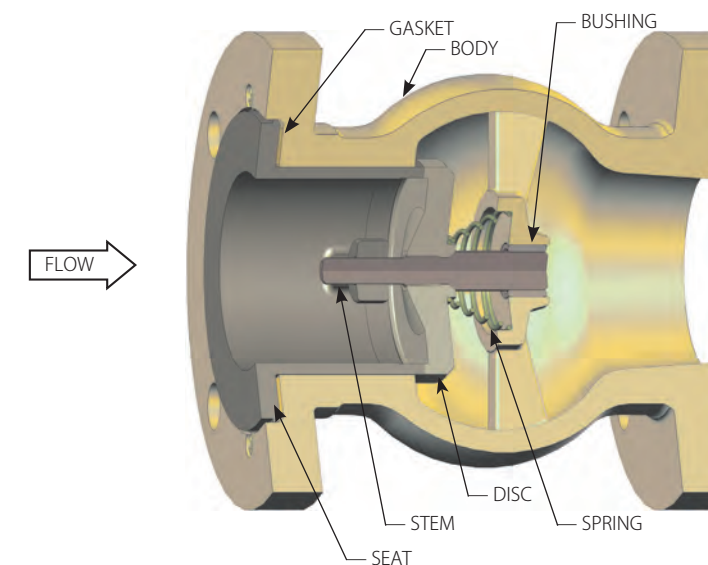

All dimensions are in inches. Weights are in pounds. For metric measurements, visit www.dft-valves.com. CP: Cracking Pressure (psig)

CODES & STANDARDS

	ALC®	Basic-Check®	DLC®	DSV®	Excalibur®	FBC®	GLC® & GLC-Cast Iron	PDC®	Restrictor Check	SCV®	SCV-R®	Vacuum Breaker	WLC® & WLC-Cast Iron	Y-Calibur™
ANSI														
B1.1	X									X	X		X	
B1.20.1		X							X	X	X	X		
B16.5	X		X		X		X	X					X	X
B16.10			X		X			X						X
B16.20					X		X	X					X	
B16.25					X					X	X			X
B16.34	X		X	X	X	X	X	X		X	X		X	X
MSS														
SP-6	X		X		X	X	X	X					X	
SP-25	X	X	X	X	X	X	X	X	X	X	X	X	X	X
SP-61	X		X	X	X	X	X (1)	X		X	X		X (1)	X
SP-125							X (2)						X (2)	
SP-126			X		X		X (3)	X		X	X		X (3)	X
SP-144														X
ASTM														
A126 CLASS B							X						X	
A216GR WCB	X				X		X	X					X	X
A351GR CF8M	X		X		X		X	X		X	X		X	X
API 6D														
6FD	X				X		X	X					X	
594	X						X (4)						X (5)	
PED	X				X		X (3)	X		X			X (3)	
CRN														
CRN	X	X (6)	X		X	X	X	X	X (6)	X		X (6)	X	X
NACE	X (7)		X (7)		X (7)		X (7)	X (7)		X (7)	X (7)		X (7)	X (7)

ANSI B1.1	Unified Inch Screw Threads	ASTM A126	CLASS B Grey Iron Castings
ANSI B1.20.1	Pipe Threads, General Purpose	ASTM A216 GR WCB	Carbon Steel Castings
ANSI 16.5	Pipe Flanges & Flanged Fittings.	ASTM A351 GR CF8M	Austenitic Steel Castings
ANSI 16.10	Face-to-Face & End-to-End Dimensions of Valves	API 6D	Pipeline Valves; Gate Valves; Plug Valves; Ball Valves; Check Valves
ANSI 16.20	Ring-Joint Gaskets & Grooves for Steel Pipe Flanges	API 6FD	Fire Test for Check Valves
ANSI 16.25	Buttwelding Ends	API 594	Wafer & Wafer-Lug Check Valves
ANSI 16.34	Valves - Flanged, Threaded & Welding Ends	PED	Pressure Equipment Directive #97/23/EC
MSS SP-6	Standard finishes for contact faces of pipe flanges and connecting end flanges of valves & fittings		
MSS SP-25	Standard marking system for valves, fittings, flanges and unions	CRN	Canadian Registration Number
MSS SP-61	Pressure testing of steel valves		
MSS SP-125	Grey Iron & Ductile Iron In-Line Check Valves	NACE MR 0175/ISO 15156	Petroleum and Natural Gas Industries-Materials for use in H2S Containing Environments in Oil and Gas Production
MSS SP-126	Steel In-Line Spring-Assisted Center Guided Check Valves	NACE MR 0103-2003	Material resistant to sulfide stress cracking in corrosive petroleum refining environments
MSS SP-144	Pressure Seal Bonnet Valves		

Notes: 1. Class 125 and 250 Cast Iron valves are leak tested in accordance with AWWA.
 2. Cast Iron Valves only.
 3. Except Cast Iron Valves.
 4. ASME Class 150 & 300, 2" to 24" only
 5. ANSI Class 600 RF and 900/1500 RF valves meet face-to-face dimensions.
 6. Contact DFT for acceptable materials.
 7. Contact DFT for NACE.

DFT in-line check valves can meet the "new" NACE Standards NACE **MR0175/ISO 15156** and NACE **MR0103-2003**. The ALC®, DLC®, Excalibur®, GLC®, GPV™, PDC®, SCV®, SCV-R®, WLC®, Y-Calibur™ can be constructed of the proper materials depending on the applicable NACE standard.

Prior to April 2003, all NACE applications were handled by NACE Standard MR0175. Compliance allowed 316 (CF8M) body material, 316 stainless steel (CF8M) trim with an Inconel® X-750. In April 2003, the requirements changed with the introduction of NACE MR0103-2003 and the updating of NACE MR0175 to NACE MR0175/ISO 15156.

NACE MR0103-2003 – "Material Resistant to Sulfide Stress Cracking in Corrosive Petroleum Refining Environments" in April 2003 applies to "refinery" applications. The material restrictions imposed by this standard relate to potential failures due to sulfide stress cracking (SSC). Typical material selection consists of WCB or 316 (CF8M) body material, 316 stainless steel (CF8M) trim with an Inconel® X-750.

NACE MR0175/ISO 15156 – "Petroleum and Natural Gas Industries – Materials for Use in H₂S-Containing Environments in Oil and Gas Production" developed with the European Federation of Corrosion replaced the original MR0175. The new standard primarily pertains to "oil field" applications and is concerned with sulfide stress cracking (SSC), chloride stress corrosion cracking, hydrogen-induced cracking and stepwise cracking, stress oriented hydrogen-induced cracking, soft zone cracking and galvanically-induced hydrogen stress. In order to select materials of construction it is necessary to know the H₂S and Chloride content, pH, operating temperatures, etc. Because of the information required, the standard makes the end user responsible for the proper selection of materials and their performance. It also limits the use of Austenitic Stainless Steels (i.e. 316 stainless steel, CF8M) and certain High Alloy Austenitic Stainless Steels (i.e. Alloy 20) to operating temperatures less than 140°F (60°C). Other stainless materials and alloys are used for temperatures greater than 140°F.

There are three parts to the standard that must be considered for material selection:

- 1) General Principles for the Selection of Cracking-Resistant Materials
- 2) Cracking-Resistant Carbon and Low Alloy Steels
- 3) Cracking-Resistant Corrosion-Resistant Alloys (CRA's) and Other Alloys.

A detailed explanation of the "new" NACE standards can be found at the DFT web site www.dft-valves.com. You can also contact DFT Engineering at 610-363-8903 or 800-206-4013 to discuss material selections for DFT non-slam check valves to your NACE requirements.

When contacting DFT for NACE material recommendations, please provide the following information:

NACE MR0103-2003

Line size
 ASME/ANSI Class
 Design pressure & temperature
 Operating pressure & temperature
 Fluid

MR0175/ISO 15156

Line size
 ASME/ANSI Class
 Design pressure & temperature
 Operating pressure & temperature
 Fluid
 pH
 H₂S content
 Chloride content

Pressure - Temperature Ratings

WCB (1)						
TEMP. (°F)	WORKING PRESSURE BY CLASS (PSIG)					
	150	300	600	900	1500	2500
-20	285	740	1480	2220	3705	6170
100	285	740	1480	2220	3705	6170
200	260	680	1360	2035	3395	5655
250 (2)	245	665	1335	2000	3330	5550
300	230	655	1310	1965	3270	5450
400 (3)	200	635	1265	1900	3170	5280
450 (4)	185	620	1235	1855	3090	5150
470 (5)	175	610	1220	1835	3060	5100
500	170	605	1205	1810	3015	5025
600	140	570	1135	1705	2840	4730
650	125	550	1100	1650	2745	4575
700 (6)	110	530	1060	1590	2665	4425
750	95	505	1015	1520	2535	4230
800	80	410	825	1235	2055	3430

CF8M (1)						
TEMP. (°F)	WORKING PRESSURE BY CLASS (PSIG)					
	150	300	600	900	1500	2500
-462	275	720	1440	2160	3600	6000
100	275	720	1440	2160	3600	6000
200	235	620	1240	1860	3095	5160
250 (2)	225	590	1180	1770	2945	4910
300	215	560	1120	1680	2795	4660
400 (3)	195	515	1025	1540	2570	4280
450 (4)	180	495	990	1485	2480	4130
470 (5)	175	490	975	1465	2440	4070
500	170	480	955	1435	2390	3980
600	140	450	900	1355	2255	3760
650	125	440	885	1325	2210	3680
700 (6)	110	435	870	1305	2170	3620
750	95	425	855	1280	2135	3560
800	80	420	845	1265	2110	3520
850	65	420	835	1255	2090	3480
900	50	415	830	1245	2075	3460
950	35	385	775	1160	1930	3220
1000	20	365	725	1090	1820	3030
1050 (7)	20	360	720	1080	1800	3000
1100 (7)	20	305	610	915	1525	2545

PRESSURE TEMPERATURE RATING FOR CAST IRON (PSIG) (8, 9)

TEMP. (°F)	CLASS 125		CLASS 250	
	2 1/2" to 12"	14" +	2 1/2" to 12"	14" +
0-150°	200 psig	150 psig	400 psig	300 psig
200° Max (1)	190 psig	135 psig	370 psig	280 psig

MAXIMUM OPERATING TEMPERATURES OF MATERIALS (10)

MATERIALS	SOFT SEAT			SPRING			
	BUNA-N	EPDM	VITON® & TFE-EN-CAPSULATED VITON®	ZELON® (11)	316 SS	INCONEL® X-750	HASTELLOY® C
TEMP. (°F)	-70 to 250	-75 to 300	-40 to 400	37 to 470	-460 to 450	-460 to 700	-460 to 1000

- Notes:**
1. Pressure/temperature ratings in accordance with ASME/ANSI B16.34-2013.
 2. Maximum temperature for Buna-N.
 3. Maximum temperature for Viton® & Zelon® with 3600 CWP SCV.
 4. Maximum temperature for 316 SS spring.
 5. Maximum temperature for Zelon with 750 CWP SCV.
 6. Maximum temperature for Inconel® X-750 spring.

7. Butt weld end valves only. Flanged ratings terminate at 1000° F.
8. 316 stainless steel trim recommended for temperatures from 180° F to 200° F.
9. Not recommended for gas or steam service.
10. Maximum valve temperature rating is limited by seal and spring materials shown above.
11. Zelon is recommended for steam service.

Pressure - Temperature Ratings

CK3MCUN (DUPLEX SS) (1)						
TEMP. (°F)	WORKING PRESSURE BY CLASS (PSIG)					
	150	300	600	900	1500	2500
-20	290	750	1500	2250	3750	6250
100	290	750	1500	2250	3750	6250
200	260	745	1490	2230	3720	6200
250 (2)	245	705	1410	2115	3525	5880
300	230	665	1335	2000	3335	5560
400 (3)	200	615	1230	1845	3070	5120
450 (4)	185	595	1195	1790	2985	4980
500	170	580	1160	1740	2905	4840
600	140	555	1115	1670	2785	4640
650	125	545	1095	1640	2735	4560
700 (5)	110	540	1085	1625	2710	4520
750	95	530	1065	1595	2660	4430

CW-12 MW (CAST HASTELLOY® "C") (1)						
TEMP. (°F)	WORKING PRESSURE BY CLASS (PSIG)					
	150	300	600	900	1500	2500
-325	230	600	1200	1800	3000	5000
100	230	600	1200	1800	3000	5000
200	210	550	1105	1655	2760	4600
250 (2)	205	535	1070	1605	2680	4470
300	200	520	1040	1560	2605	4340
400 (3)	190	490	980	1470	2450	4080
450 (4)	180	475	950	1430	2380	3970
500	170	465	925	1390	2315	3860
600	140	440	880	1320	2195	3660
650	125	430	860	1290	2150	3580
700 (5)	110	420	835	1255	2090	3480
750	95	410	820	1230	2050	3420
800	80	400	800	1200	2005	3340
850	65	395	785	1180	1970	3280
900	50	385	775	1160	1930	3220
950	35	380	760	1140	1895	3160
1000	20	365	725	1090	1820	3030

CN7M (CAST ALLOY 20) (1)						
TEMP. (°F)	WORKING PRESSURE BY CLASS (PSIG)					
	150	300	600	900	1500	2500
-325	230	600	1200	1800	3000	5000
100	230	600	1200	1800	3000	5000
200	200	520	1035	1555	2590	4320
250 (2)	190	490	980	1475	2460	4100
300	180	465	930	1395	2330	3880
400 (3)	160	420	845	1265	2110	3520
450 (4)	155	405	810	1215	2025	3380
500	150	390	780	1165	1945	3240
600	140	360	720	1080	1800	3000

HASTELLOY® C-276 AND INCONEL® 625 (1) (8)						
TEMP. (°F)	WORKING PRESSURE BY CLASS (PSIG)					
	150	300	600	900	1500	2500
-325	290	750	1500	2250	3750	6250
100	290	750	1500	2250	3750	6250
200	260	750	1500	2250	3750	6250
250 (2)	245	740	1475	2215	3695	6160
300	230	730	1455	2185	3640	6070
400 (3)	200	700	1395	2095	3490	5820
450 (4)	185	680	1360	2045	3405	5680
500	170	665	1330	1995	3325	5540
600	140	605	1210	1815	3025	5040
650	125	590	1175	1765	2940	4905
700 (5)	110	570	1135	1705	2840	4730
750	95	530	1065	1595	2660	4430
800	80	510	1015	1525	2540	4230
850	65	485	975	1460	2435	4060
900	50	450	900	1350	2245	3745
950	35	385	775	1160	1930	3220
1000	20	365	725	1090	1820	3030
1050 (6)	20	360	720	1080	1800	3000
1100 (6)	20	325	645	965	1610	2685
1150 (6)	20	275	550	825	1370	2285
1200 (7)	20	205	410	615	1030	1715
1250 (6)	20	165	330	495	825	1370

LCC (LOW CARBON CARBON STEEL) (1)						
TEMP. (°F)	WORKING PRESSURE BY CLASS (PSIG)					
	150	300	600	900	1500	2500
-50	290	750	1500	2250	3750	6250
100	290	750	1500	2250	3750	6250
200	260	750	1500	2250	3750	6250
250 (2)	245	740	1475	2215	3695	6160
300	230	770	1455	2185	3640	6070
400 (3)	200	705	1405	2110	3520	5865
450 (4)	185	685	1365	2050	3420	5700
500	170	665	1330	1995	3325	5540
600	140	605	1210	1815	3025	5040
650	125	590	1175	1765	2940	4905

NAB (NICKEL-ALUMINUM BRONZE)

TEMP. (°F)	WORKING PRESSURE BY CLASS (PSIG)	
	150	300
100	275	720
200	215	550
300	185	520
400	155	390
500	115	300

- Notes:**
1. Pressure/temperature ratings in accordance with ASME/ANSI B16.34-2013.
 2. Maximum temperature for Buna-N.
 3. Maximum temperature for Viton® & Zelon® with 3600 CWP SCV.
 4. Maximum temperature for 316 SS spring.
 5. Maximum temperature for Inconel® X-750 spring.
 6. Butt weld end valves only. Flanged ratings terminate at 1000° F.
 7. Maximum temperature for Inconel® 625.
 8. Only bar stock grades in accordance with ASME/ANSI B16.34-2013.

Flange Dimensions

ANSI CLASS	NOMINAL PIPE SIZE	OUTSIDE DIAMETER OF FLANGE	OUTSIDE DIAMETER OF RAISED FACE	THICKNESS OF FLANGE t _f	DIAMETER OF BOLT CIRCLE	DIAMETER OF BOLT HOLES	NUMBER OF BOLTS	DIAMETER OF BOLTS
150	3/4	3.88	1.69	0.44	2.75	0.62	4	0.50
	1	4.25	2.00	0.50	3.12	0.62	4	0.50
	1 1/2	5.00	2.88	0.62	3.88	0.62	4	0.50
	2	6.00	3.62	0.69	4.75	0.75	4	0.62
	3	7.50	5.00	0.88	6.00	0.75	4	0.62
	4	9.99	6.19	0.88	7.50	0.75	8	0.62
	6	11.00	8.50	0.94	9.50	0.88	8	0.75
	8	13.50	10.62	1.06	11.75	0.88	8	0.75
	10	16.00	12.75	1.12	14.25	1.00	12	0.87
	12	19.00	15.00	1.19	17.00	1.00	12	0.87
	14	21.00	16.25	1.31	18.75	1.12	12	1.00
	16	23.50	18.50	1.38	21.25	1.12	16	1.00
300	18	25.00	21.00	1.50	22.75	1.25	16	1.12
	20	27.50	23.99	1.62	25.00	1.25	20	1.12
	24	32.00	27.25	1.82	29.50	1.38	20	1.25
	3/4	4.62	1.69	0.56	3.25	0.75	4	0.62
	1	4.88	2.00	0.62	3.50	0.75	4	0.62
	1 1/2	6.12	2.88	0.75	4.25	0.88	4	0.75
	2	6.50	3.62	0.81	5.00	0.75	8	0.62
	3	8.25	5.00	1.06	6.62	0.88	8	0.75
	4	10.00	6.19	1.19	7.88	0.88	8	0.75
	6	12.50	8.50	1.38	10.62	0.88	12	0.75
	8	15.00	10.62	1.56	13.00	1.00	12	0.87
	10	17.50	12.75	1.82	15.25	1.12	16	1.00
600	12	20.50	15.00	1.94	17.75	1.25	16	1.12
	14	23.00	16.25	2.06	20.25	1.25	20	1.12
	16	25.50	18.50	2.19	22.50	1.38	20	1.25
	18	28.00	21.00	2.31	24.75	1.38	24	1.25
	20	30.50	23.00	2.44	27.00	1.38	24	1.25
	1	4.88	2.00	0.69	3.50	0.75	4	0.62
	1 1/2	6.12	2.88	0.88	4.50	0.88	4	0.75
	2	6.50	3.62	1.00	5.00	0.75	8	0.62
	3	8.25	5.00	1.25	6.62	0.88	8	0.75
	4	10.75	6.19	1.50	8.50	1.00	8	0.87
	6	14.00	8.50	1.88	11.50	1.12	12	1.00
	8	16.50	10.62	2.19	13.75	1.25	12	1.12
900	10	20.00	12.75	2.50	17.00	1.38	16	1.25
	12	22.00	15.00	2.62	19.25	1.38	20	1.25
	14	23.75	16.25	2.75	20.75	1.50	20	1.37
	16	27.00	18.50	3.00	23.75	1.62	20	1.50
	1 1/2	7.00	2.88	1.25	4.88	1.12	4	1.00
	2	8.50	3.62	1.50	6.50	1.00	8	0.87
	3	9.50	5.00	1.50	7.50	1.00	8	0.87
	4	11.50	6.19	1.75	9.25	1.25	8	1.12
	6	15.00	8.50	2.19	12.50	1.25	12	1.12
	8	18.50	10.62	2.50	15.50	1.50	12	1.37
	10	21.50	12.75	2.75	18.50	1.50	16	1.37
	1500	1 1/2	7.00	2.88	1.25	4.88	1.12	4
2		8.50	3.62	1.50	6.50	1.00	8	0.87
3		10.50	5.00	1.88	8.00	1.25	8	1.12
4		12.25	6.19	2.12	9.50	1.38	8	1.25
6	15.50	8.50	3.25	12.50	1.50	12	1.37	
8	19.00	10.62	3.62	15.50	1.75	12	1.62	

Notes:
 1. Class 150 and 300 flanges have a 0.06" raised face which is not included in the "t_f" dimension.
 2. Class 600 to 1500 have a 0.25" raised face which is not included in the "t_f" dimension.
 3. DFT's standard flange finish is 125 - 250 Ra.
 4. All dimensions are in inches
 ASME B16.5-2013 RAISED FACE

Valve Data Sheet

		TEL: (610) 363-8903 FAX: (610) 524-9242 dft@dft-valves.com www.dft-valves.com		VALVE DATA SHEET NON-SLAM CHECK VALVE "CHECK VALVE DOCTOR™"	
Customer: _____ Contact: _____ Phone: _____ Fax: _____ email: _____		Date: _____ Page: _____ of _____ QUOTE NO.: _____ ITEM NO. _____			
GENERAL INFORMATION	Quantity: *				
	Line Size: *				
	Class (ANSI/API):*				
	Model:				
	End Connections: *				
	Material: Body*				
	Trim *				
	Spring				
	Seating	Metal <input type="checkbox"/> Soft <input type="checkbox"/>			
	Gaskets/O-ring				
Bolting					
Tag No: _____	Brass ___ Stainless ___ Other: _____				
FLUID DATA	Fluid State *	Liquid <input type="checkbox"/> Gas <input type="checkbox"/> Steam <input type="checkbox"/>			
	Fluid: *				
	Specific Gravity: *				
	Design Conditions:	Pressure:	Temp.:		
	Operating Conditions:	Flow*	Pressure *	Temperature*	
	Units: (i.e. GPM, PSI, °F, etc.)	_____	_____	° _____	
	Normal *				
Maximum					
Minimum					
INSTALLATION DATA	Orientation: *	Horizontal <input type="checkbox"/> Vert. flow: Up <input type="checkbox"/> Down <input type="checkbox"/>			
	Service Application:				
SPECIAL REQUIREMENTS	Specification Nos.:				
	CE MARK	Yes <input type="checkbox"/>	No <input type="checkbox"/>		
	Cert. of Compliance:	Yes <input type="checkbox"/>	No <input type="checkbox"/>		
	CMTRs:	Body <input type="checkbox"/>	Trim <input type="checkbox"/>		
	Drawings:	Yes <input type="checkbox"/>	No <input type="checkbox"/>		
	NACE MR 0175/ISO 15156	Yes <input type="checkbox"/>	No <input type="checkbox"/>	% H ₂ S: _____	
	NACE MR 0103-2003	Yes <input type="checkbox"/>	No <input type="checkbox"/>		
	NDE: (Specify)				
	Packaging:				
	Other:				
NOTES					
DELIVERY: _____ wks.	* Denotes Required				

Valve Data Sheet

		TEL: (610) 363-8903 FAX: (610) 524-9242 dft@dft-valves.com www.dft-valves.com		VALVE DATA SHEET NON-SLAM CHECK VALVE "CHECK VALVE DOCTOR™"	
Customer: _____ Contact: _____ Phone: _____ Fax: _____ email: _____		Date: _____ Page: _____ of _____ QUOTE NO.: _____ ITEM NO. _____			
GENERAL INFORMATION	Quantity: *				
	Line Size: *				
	Class (ANSI/API):*				
	Model:				
	End Connections: *				
	Material: Body*				
	Trim *				
	Spring				
	Seating	Metal <input type="checkbox"/>	Soft <input type="checkbox"/>		
	Gaskets/O-ring				
Bolting					
Tag No: _____	Brass <input type="checkbox"/>	Stainless <input type="checkbox"/>	Other: _____		
FLUID DATA	Fluid State *	Liquid <input type="checkbox"/>	Gas <input type="checkbox"/>	Steam <input type="checkbox"/>	
	Fluid: *				
	Specific Gravity: *				
	Design Conditions:	Pressure:	Temp.:		
	Operating Conditions:	Flow*	Pressure *	Temperature*	
	Units: (i.e. GPM, PSI, °F, etc.)	_____	_____	° _____	
	Normal *				
Maximum					
Minimum					
INSTALLATION DATA	Orientation: *	Horizontal <input type="checkbox"/> Vert. flow: Up <input type="checkbox"/> Down <input type="checkbox"/>			
	Service Application:				
SPECIAL REQUIREMENTS	Specification Nos.:				
	CE MARK	Yes <input type="checkbox"/>	No <input type="checkbox"/>		
	Cert. of Compliance:	Yes <input type="checkbox"/>	No <input type="checkbox"/>		
	CMTRs:	Body <input type="checkbox"/>	Trim <input type="checkbox"/>		
	Drawings:	Yes <input type="checkbox"/>	No <input type="checkbox"/>		
	NACE MR 0175/ISO 15156	Yes <input type="checkbox"/>	No <input type="checkbox"/>	% H ₂ S: _____	
	NACE MR 0103-2003	Yes <input type="checkbox"/>	No <input type="checkbox"/>		
	NDE: (Specify)				
Packaging:					
Other:					
NOTES					
DELIVERY: _____ wks.	* Denotes Required				

Applications

Chemical Processing

Boiler Feed & Discharge
 Compressor Discharge
 Condensate Lines
 Cooling Towers
 Cryogenics
 Evaporators
 Nitrogen Purge
 Process Lines
 Pump Discharge
 Metering Pumps
 Mineral Dewatering
 Steam Lines
 Vacuum Lines & Breakers
 Water Treatment

Petroleum Production & Refining

Boiler Feed & Discharge
 Condensate Lines
 Cooling Towers
 Crude & Refined Product Lines
 Compressor Discharge
 Desalination
 Evaporators
 Generator Inlet & Discharge
 Pump Discharge
 Steam Lines
 Vacuum Lines & Breakers
 Water Treatment

Mining

Autoclaves
 Boiler Feed & Discharge
 Mine Dewatering

Pulp & Paper

Boiler Feed & Discharge
 Chemical Lines
 Condensate Lines
 Generator Inlet & Discharge
 Metering Pumps
 Pump Discharge
 Steam Lines
 (Digester & Paper Machines)
 Water Treatment

Textiles

Boiler Feed & Discharge
 Chemical Dye Lines
 Compressor Discharge
 Condensate Lines
 Metering Pumps
 Pump Discharge
 Steam Lines

Power Generation

Boiler Feed & Discharge
 Compressor Discharge
 Cooling Towers
 Desalination
 Evaporators
 Pump Discharge
 Steam Lines
 Vacuum System
 (Fly Ash System)
 Water Lines

Food, Beverage & Drug

Autoclaves
 Boiler Feed & Discharge
 Chemical Lines
 Compressor Discharge
 Condensate Lines
 Cookers
 Evaporators
 Metering Pumps
 Pump Discharge
 Refrigeration (Hot Gas Defrost)
 Steam Lines
 Vacuum Lines & Breakers

Primary Metals

Chemical Lines
 Compressor Discharge
 Condensate Lines
 Extrusion Equipment
 Evaporators
 Hydraulic Lines
 Presses - Water Inlet & Outlet
 Pump Discharge
 Steam Lines
 Water Lines
 Water Treatment

Building Maintenance

Condensate Lines
 Compressor Discharge
 Pump Discharge
 Steam Lines
 Water Lines

Warranty

Each DFT® INC. (DFT) product is warranted against defects in material and workmanship for a period of one year after being placed in service, but not exceeding 18 months after shipment, when these products are properly installed, maintained and used within the service and temperature and pressure ranges for which they were designed and manufactured, and provided they have not been subject to accident, negligence, alteration, abuse, misuse or the like. This warranty extends to the first purchaser only. All defective material must be returned to the person from whom you purchased the product, transportation prepaid, free of any liens or encumbrances and if found to be defective will be repaired free of charge or replaced, at the warrantor's or DFT's option.

FOR A COMPLETE UNDERSTANDING OF YOUR SOLE AND EXCLUSIVE LEGAL RIGHTS AND REMEDIES, AND THE PROCEDURES TO BE FOLLOWED WITH RESPECT TO ANY CLAIMS, PLEASE REFER TO THE "LIMITATION AND DISCLAIMER OF WARRANTIES AND LIABILITIES," AVAILABLE ON REQUEST FROM DFT. THE EXPRESS WARRANTIES SET FORTH IN THAT DOCUMENT AND THE OBLIGATIONS AND LIABILITIES OF DFT THEREUNDER ARE EXCLUSIVE AND ARE EXPRESSLY IN LIEU OF ALL OTHER WARRANTIES, EXPRESS OR IMPLIED, INCLUDING, WITHOUT LIMITATION, THE WARRANTIES OF MERCHANTABILITY AND FITNESS FOR A PARTICULAR PURPOSE, AND ALL OTHER OBLIGATIONS AND LIABILITIES OF DFT. IT IS UNDERSTOOD THAT THERE ARE NO WARRANTIES WHICH EXTEND BEYOND THE DESCRIPTION OF THE EXPRESS TERMS IN THE "LIMITATION AND DISCLAIMER OF WARRANTIES AND LIABILITIES." UNDER NO CIRCUMSTANCES SHALL DFT BE LIABLE FOR ANY CONSEQUENTIAL, INCIDENTAL, ECONOMIC, DIRECT, INDIRECT, GENERAL OR SPECIAL DAMAGES, EXPENSES OR LOSSES RELATING TO ANY BREACH OF WARRANTIES.

It is expressly understood and agreed that unless a statement is specifically identified in this brochure as a warranty, the statements made herein relating to DFT's products are not express warranties, but are merely for informational, illustrative and identification purposes only.



DFT® INC.

140 Sheree Blvd., P.O. Box 566, Exton, PA 19341-0566

610-363-8903

800-206-4013

FAX 610-524-9242

e-mail: dft@dft-valves.com

internet: www.dft-valves.com



REPRESENTED BY

DFT®
INC.