

Tufline[®] Lined Ball Valves

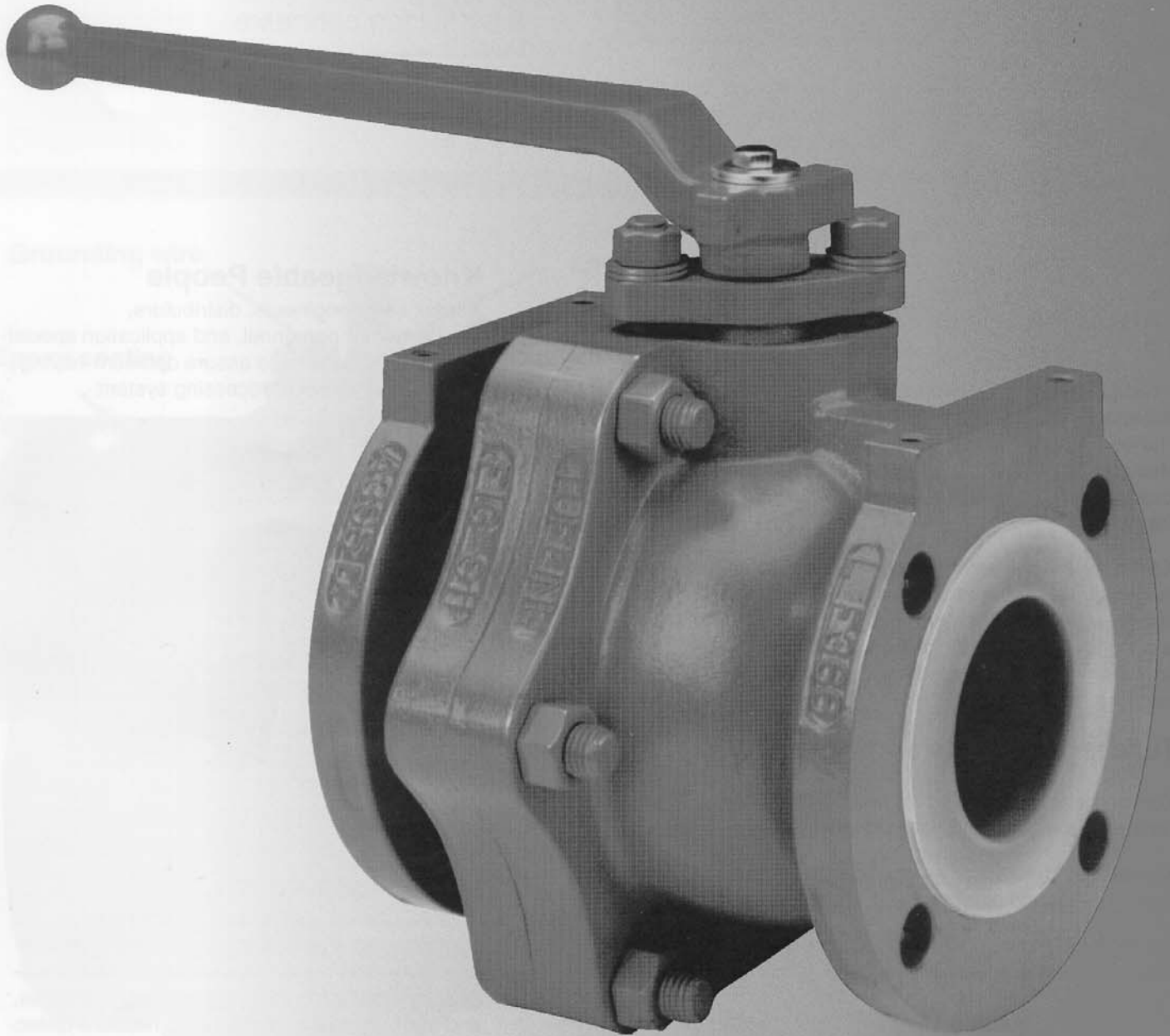

XOMOX[®]
Process Valves & Actuators

Contents /	Page
Xomox Overview	2
900 Series Overview	3
Figures 911 & 944	4-5
Figures 911XP & 944XP	6-7
Figure R202	8
Materials of Construction & Pressure-Temperature Ratings	9
Lining Materials Data	10
Options and Ordering Information	11

Lined valves versus alloys

Tufline lining materials are impervious to all but a few rarely encountered corrosive fluids.

Fluctuations in processing temperatures or chemical concentration also have little or no effect on the Tufline lining.

Since there is no need to stock and carefully match different alloy valves for every application, you save on valve inventory and avoid costly installation errors.

Xomox Corporation Profile

Xomox is an international manufacturer of process valves, actuators, and flow control products for industrial markets.

Headquartered in Cincinnati, Ohio, Xomox also has manufacturing facilities in Germany, England, France, Hungary, India, Japan, Taiwan, Korea, Mexico, Brazil, and Canada. Sales offices are located in major cities in the U.S. and throughout the world.

Xomox is a subsidiary of Crane Co., a diversified manufacturer of engineered industrial products headquartered in Stamford, Connecticut. Crane Co. is a worldwide operation, diversified in aerospace, engineered materials, merchandising systems, fluid handling, and controls.

Tufline® Products Profile

Xomox manufactures and markets Tufline corrosion resistant plug, ball, and butterfly valves.

Xomox also manufactures and markets a complete line of pneumatic actuators and lined accessories.

Some of the most versatile, reliable, and state-of-the-art valving products are detailed in this catalog.

Knowledgeable People

Xomox sales engineers, distributors, service center personnel, and application specialists all work together to assure optimum valving performance in your processing system.



Quality assurance

Tufline lined valves are used successfully in numerous applications throughout the chemical process industries. Xomox quality control procedures assure lining integrity, seat leak tightness, and absence of external leaks. Liners are dielectrically spark tested at 20,000 volts in accordance with S.P.I. specifications. Valves are available specifically tested and tagged to indicate conformity to ANSI B16.34 or B16.42 shell tests, and MSS SP-61 test requirements.

© Copyright Xomox Corporation 1990, 2007.
All rights reserved. Xomox®, Tufline®, Tufline XP®, and Matryx® are registered trademarks of Xomox Corporation. Xomox XRP is a trademark of the Xomox Corporation. Teflon® and Viton® are registered trademarks of DuPont.



Tufline 900 Series Lined Ball Valves

Figures	Description
911	Full-port
911XP	Full-port with extended packing
944	Standard port
944XP	Standard port with extended packing

Standard face-to-face dimensions

All 900 series ball valves conform to ANSI B16.10 dimensional specifications for short pattern flanged end ball valves.

The 911 valves are both standard length and full port designed which means your processing system can be more compact, efficient, and economical.

The standard port 944 provides an even more competitive alternative to the full port 911. Operation torques are correspondingly lower to provide for easier operation and lower actuation costs.

Both designs are available with the "XP" extended packing option for improved emissions control.

Features

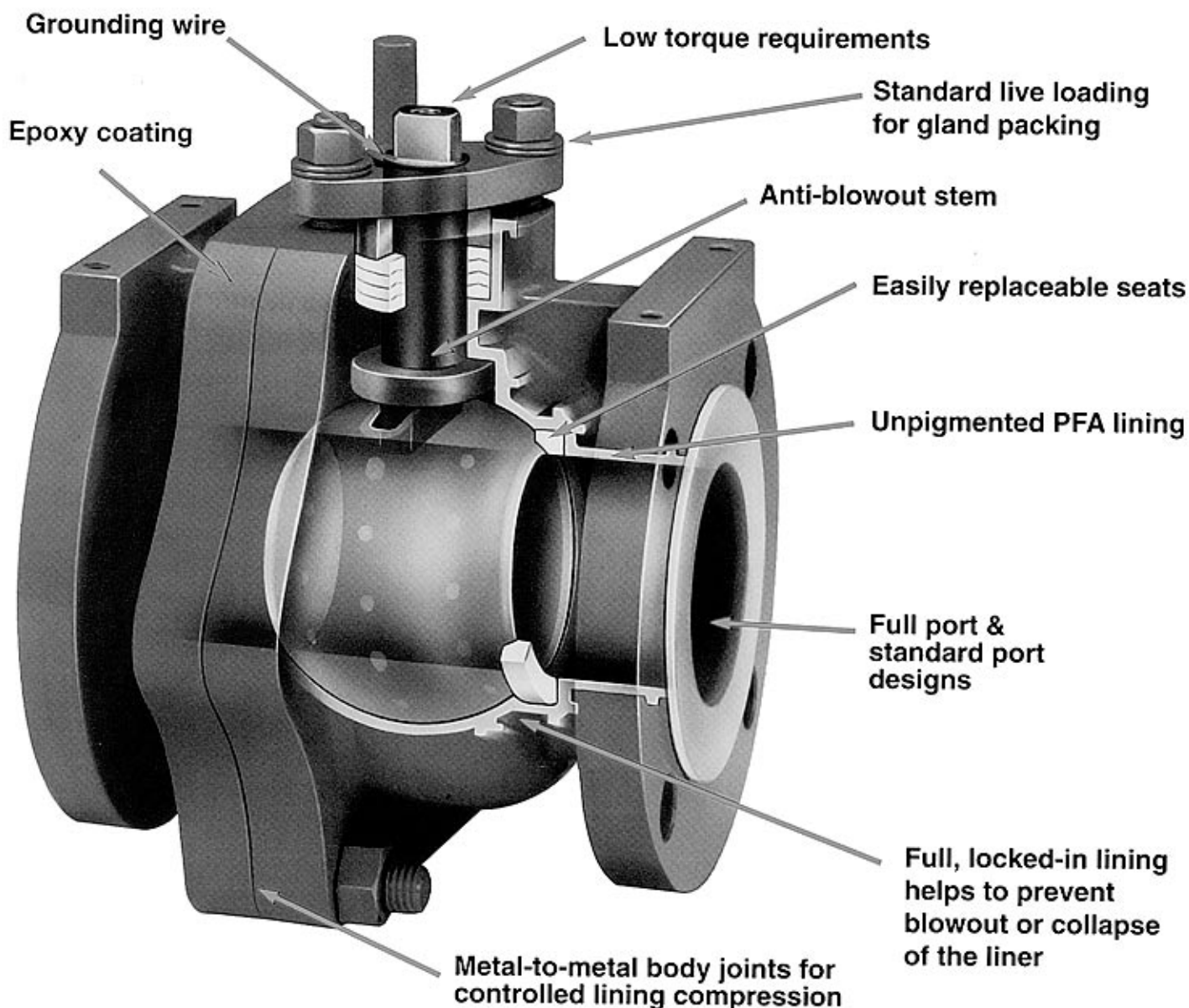

911

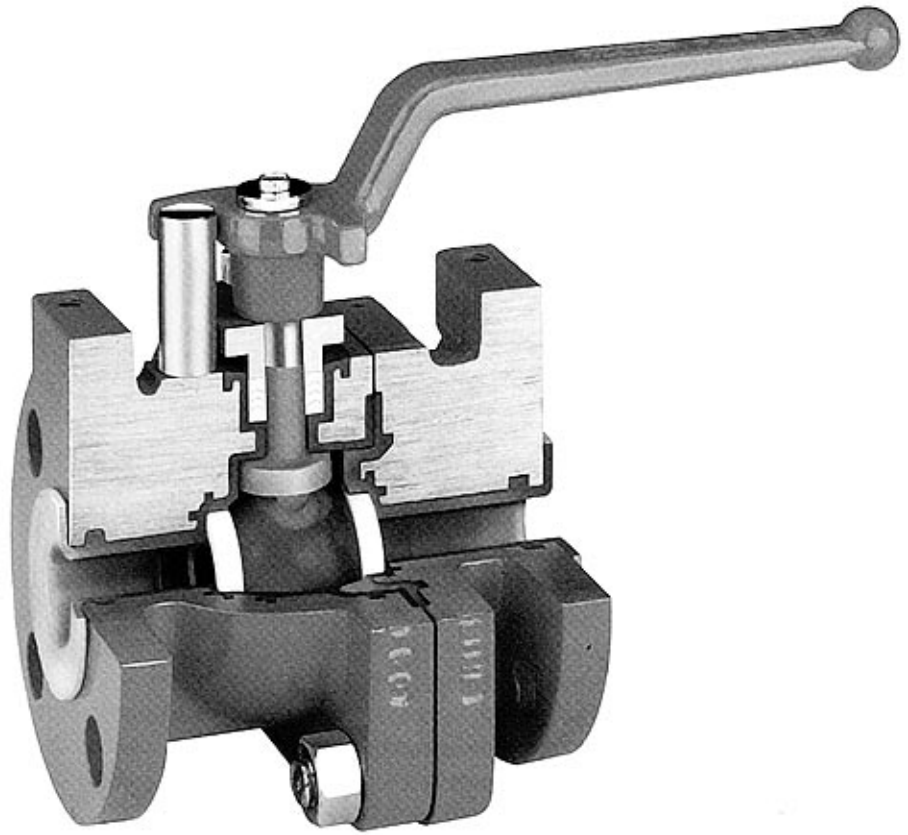

944

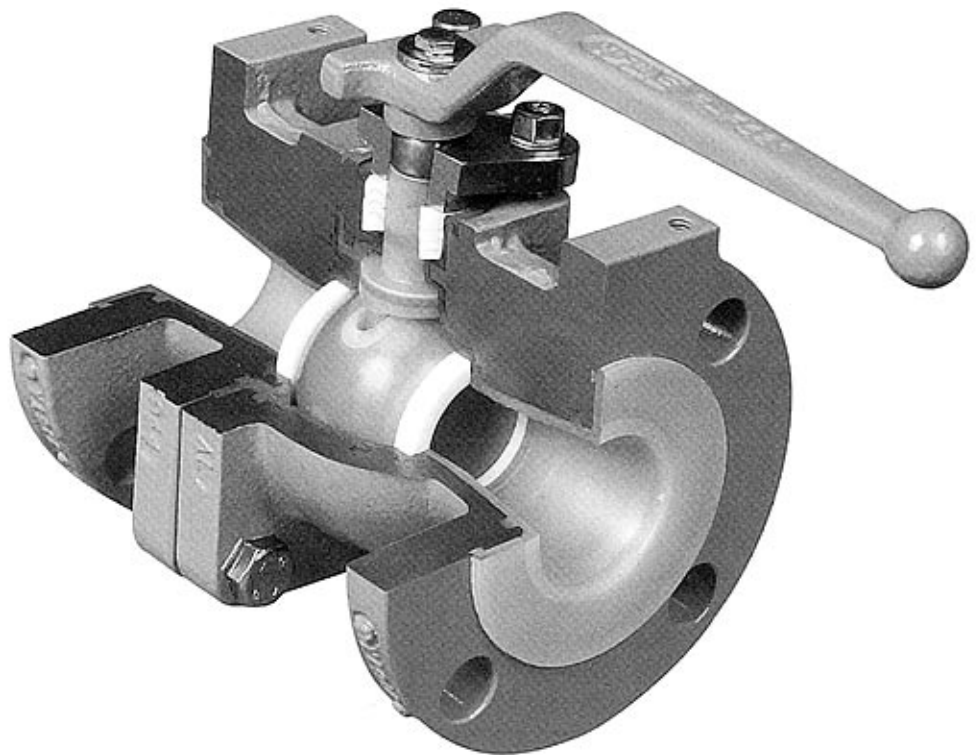

Dimensional Chart

Size	L	M	Q	HT	G	A	F	B	N ¹	P	O
1	5.02	2.73	8.00	5.04	2.00	.91	.09	.52	4	3.13	.63
1 1/2	6.51	3.50	8.00	5.54	2.88	1.42	.09	.63	4	3.88	.63
2	7.02	3.74	8.00	6.03	3.63	1.85	.12	.69	4	4.75	.75
3	8.02	4.22	11.50	8.02	4.75	2.85	.12	.82	4	6.00	.75
4	9.02	4.76	9.00	10.70	6.19	3.70	.12	1.01	8	7.50	.75
6	10.52	5.26	12.00	11.85	8.13	5.70	.13	1.07	8	9.50	.88

Operating Characteristics

Size	Torque ²	Cv	Wt. ³
1	115	57	12
1 1/2	165	213	19
2	295	295	28
3	720	670	54
4	1210	1400	99
6	1800	3000	149

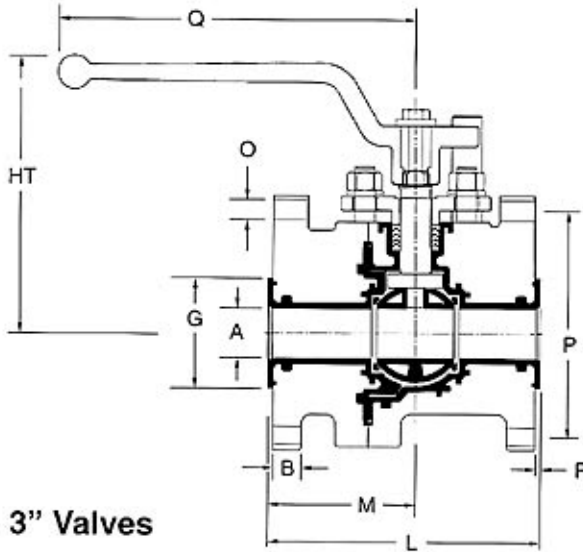

1" - 3" Valves

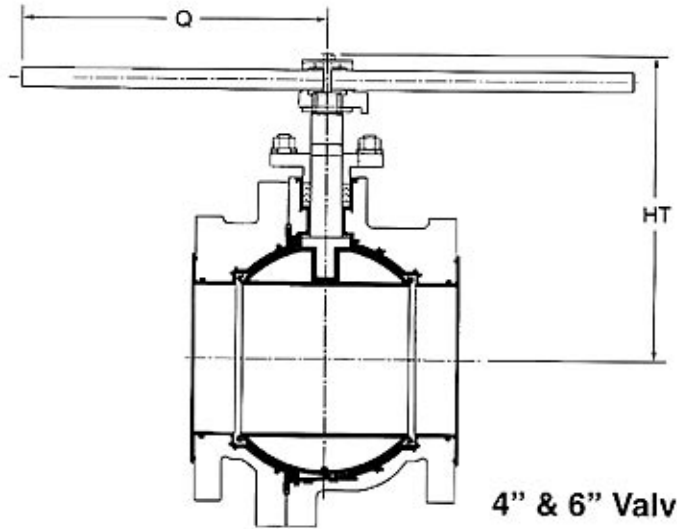

4" & 6" Valves

Dimensional Chart

Size	L	M	Q	HT	G	A	F	B	N ¹	P	O
1	5.02	2.73	8.00	5.04	2.00	.91	.09	.52	4	3.13	.63
1 1/2	6.51	3.50	8.00	5.04	2.88	.91	.09	.63	4	3.88	.63
2	7.02	3.74	8.00	5.54	3.63	1.42	.12	.69	4	4.75	.75
3	8.02	4.22	8.00	6.03	4.75	1.85	.12	.82	4	6.00	.75
4	9.02	4.76	11.50	8.02	6.19	2.85	.12	1.01	8	7.50	.75
6	10.52	5.26	9.00	10.70	8.13	3.70	.13	1.07	8	9.50	.88
8	11.50	5.59	12.00	11.85	10.63	5.70	.13	1.18	8	11.75	.88

Operating Characteristics

Size	Torque ²	Cv	Wt. ³
1	115	57	12
1 1/2	115	50	15
2	165	171	25
3	295	203	36
4	720	549	70
6	1210	610	112
8	1800	1075	170

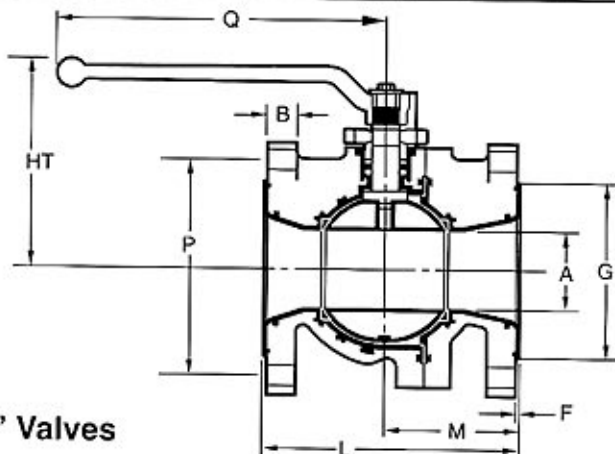

1" - 4" Valves

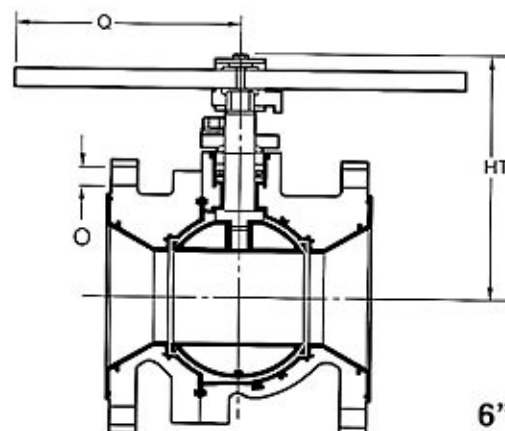

6" & 8" Valves 5

- ¹ Number of bolt holes
- ² units are inch-lbs
- ³ units are lbs

XP option Valves

All XP ball valves come with a monitoring/injection port (Not shown in this view)

Live loaded spring washers provide constant, uniform packing pressure.

Carbon graphite filled PTFE end ring acts as the static eliminator and also prevents packing extrusion

Carbon graphite filled PTFE lantern ring provides a path for monitoring packing performance

Two sets of PTFE chevron packing rings provide a tight pressure-assisted stem seal

Metal-to-metal body joints for controlled lining compression

Full, locked-in PFA lining throughout body and packing area helps to prevent blowout or collapse of the liner

Epoxy coating

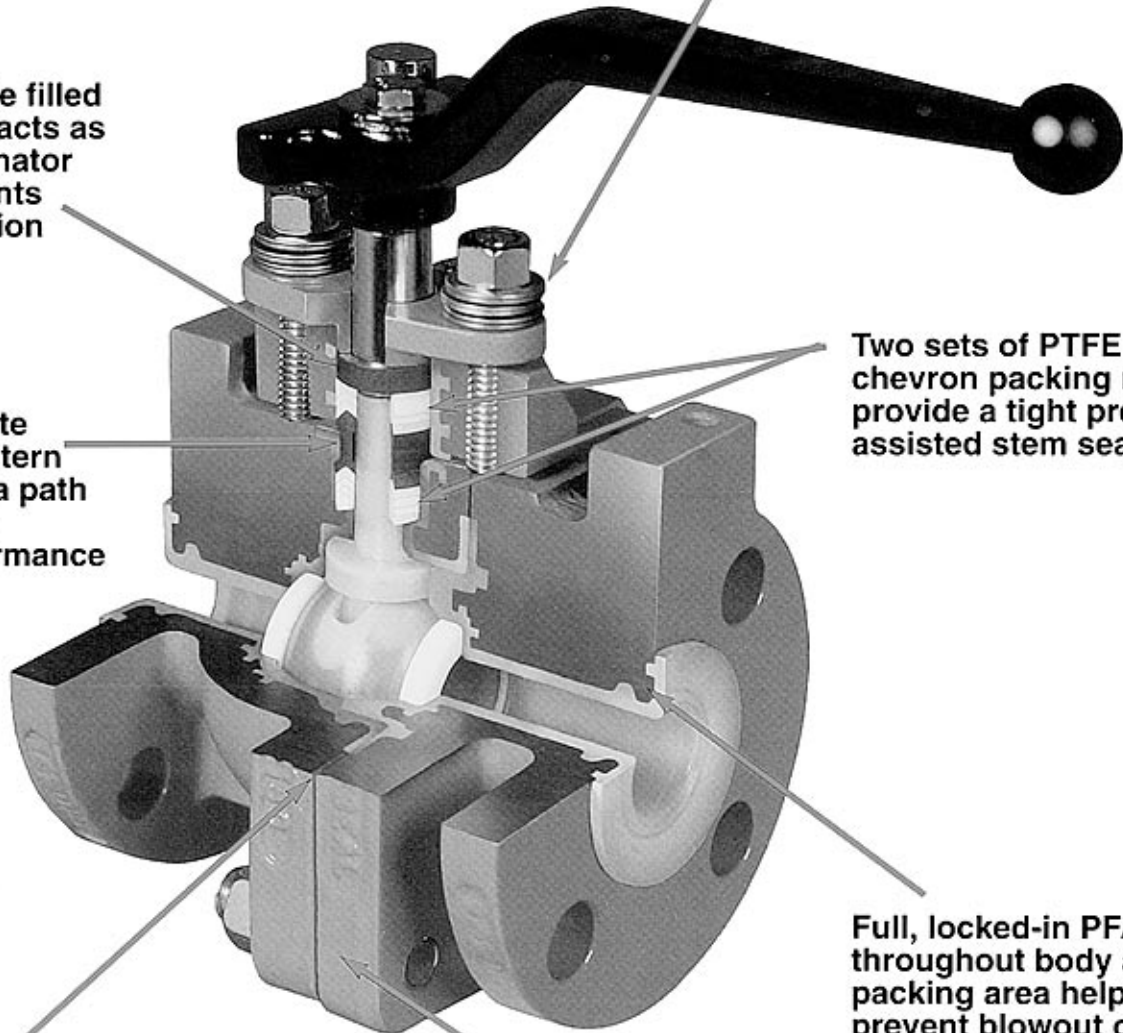

Dimensional Chart

Size	L	M	Q	HT	H1	G	A	F	B	N ¹	P	O
1	5.02	2.73	8.00	5.90	2.68	2.00	.91	.09	.52	4	3.13	.63
1½	6.51	3.50	8.00	6.59	3.25	2.88	1.42	.09	.63	4	3.88	.63
2	7.02	3.74	8.00	7.03	3.64	3.63	1.85	.12	.69	4	4.75	.75
3	8.02	4.22	11.50	9.38	5.05	4.75	2.85	.12	.82	4	6.00	.75
4	9.02	4.76	9.00	11.50	6.64	6.19	3.70	.12	1.01	8	7.50	.75
6	10.52	5.26	12.00	12.75	7.78	8.13	5.70	.13	1.07	8	9.50	.88

Operating Characteristics

Size	Torque ²	Cv	WT. ³
1	127	57	14
1½	182	213	24
2	325	295	33
3	792	670	59
4	1331	1400	103
6	1980	3000	153

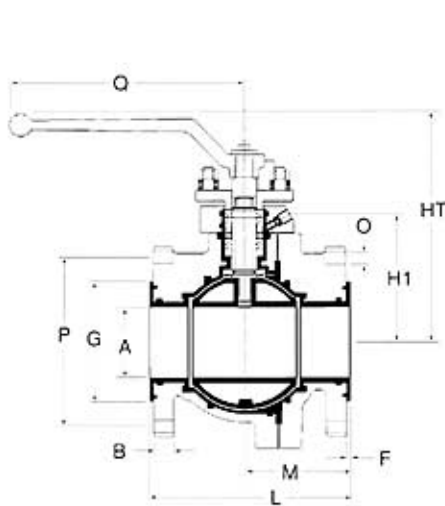

1" - 3" Valves

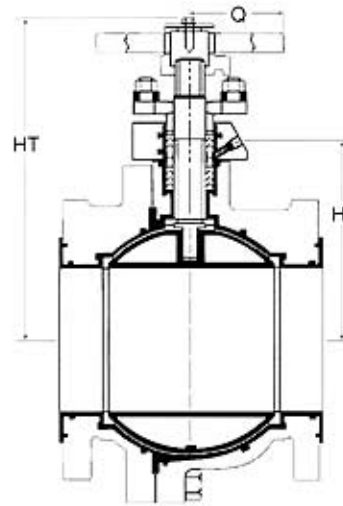

4" & 6" Valves

Dimensional Chart

Size	L	M	Q	HT	H1	G	A	F	B	N ¹	P	O
1	5.02	2.73	8.00	5.90	2.68	2.00	.91	.09	.52	4	3.13	.63
1½	6.51	3.50	8.00	5.90	2.68	2.88	.91	.09	.63	4	3.88	.63
2	7.02	3.74	8.00	6.59	3.25	3.63	1.42	.12	.69	4	4.75	.75
3	8.02	4.22	8.00	7.03	3.64	4.75	1.85	.12	.82	4	6.00	.75
4	9.02	4.76	11.50	9.38	5.05	6.19	2.85	.12	1.01	8	7.50	.75
6	10.52	5.26	9.00	11.50	6.64	8.13	3.70	.13	1.07	8	9.50	.88
8	11.50	5.59	12.00	12.75	7.88	10.63	5.70	.13	1.18	8	11.75	.88

Operating Characteristics

Size	Torque ²	Cv	WT. ³
1	127	57	14
1½	127	50	17
2	182	171	28
3	325	203	40
4	792	549	75
6	1331	610	116
8	1980	1075	174

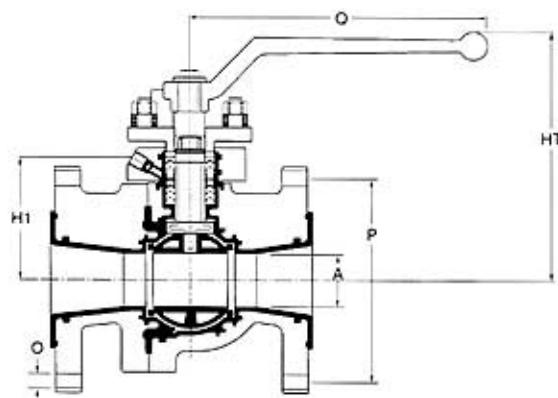

1" - 4" Valves

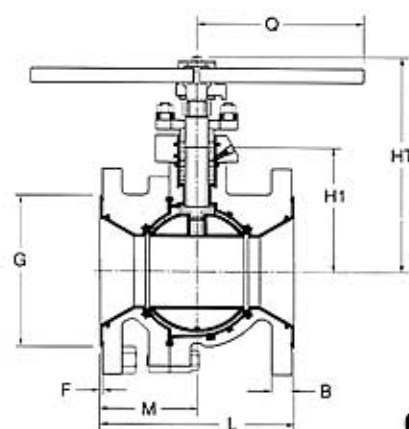

- 1 Number of bolt holes
- 2 units are inch-lbs
- 3 units are lbs

6" & 8" Valves 7

R-202 (Formerly 091A)

The Tufline 091A full port lined ball valve is a non-standard face-to-face valve.*
The 091A is available in sizes 1/2" - 12", Class 150.

Pressure-temperature ratings

Maximum differential pressure at shut-off - for 091A

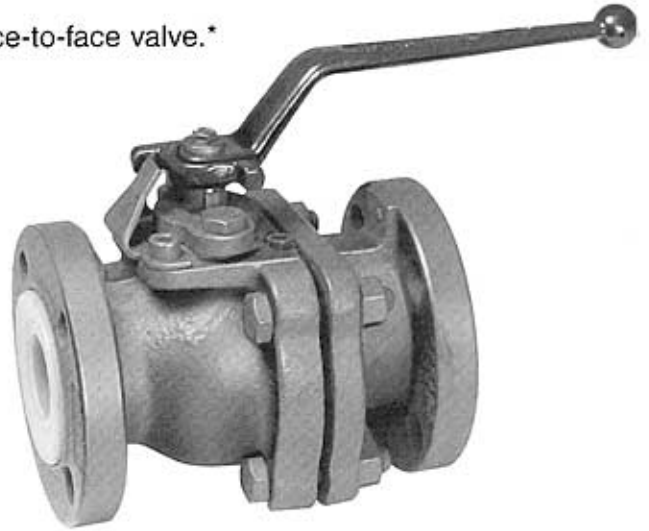
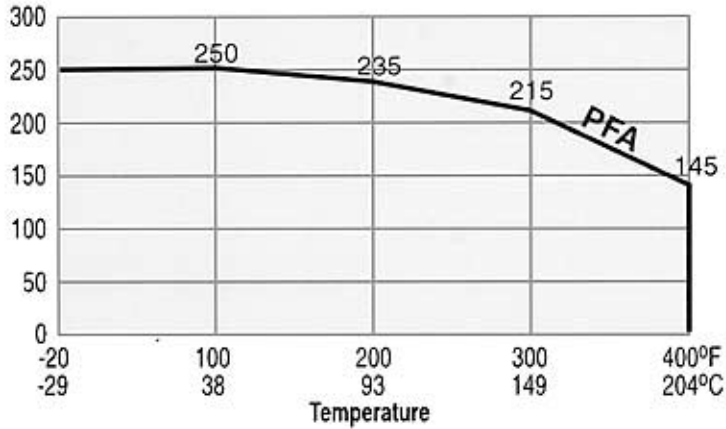

091A Dimensional Table

Size	C	M	D	E	G	A	F	B	N ¹	P	O
1/2	5.12	2.25	6.70	4.50	1.57	.60	.157	0.55	4	2.38	1/2-13
3/4	5.90	2.56	6.70	4.50	1.97	.80	.197	0.63	4	2.75	1/2-13
1	6.00	2.37	6.70	4.50	2.00	.91	.197	0.59	4	3.12	0.62
1 1/2	7.00	2.96	7.90	5.30	2.88	1.42	.197	0.71	4	3.88	0.62
2	8.00	3.43	7.90	6.10	3.63	1.85	.197	0.76	4	4.75	0.75
3	9.50	4.65	11.50	7.70	4.92	3.05	.197	0.94	4	6.00	0.75
4	11.50	5.32	20.00	8.85	6.18	3.70	.197	1.06	8	7.50	0.75
6	14.00	7.48	20.00	10.00	8.50	5.70	.197	1.12	8	9.50	0.88
8	18.00	9.00	-	-	10.30	7.87	.197	1.34	8	11.80	0.87
10/8*	13.00	6.50	-	-	12.60	7.87	.197	1.34	12	14.30	1.00
12	24.00	12.00	-	-	14.45	11.81	.197	1.57	10	17.0	1.18

Operating Characteristics

Size	Torque ²	Cv	Wt. ³
1/2	62	13	8
3/4	62	35	10
1	62	57	10
1 1/2	124	213	18
2	230	295	25
3	531	670	65
4	797	1400	110
6	1239	2125	167
8	4450	9764	440
10/8*	4450	3523	440
12	15930	-	800

¹ Number of bolt holes
- Gear operated only.
* 10/8 is a short, face-to-face standard port lined ball valve.

² Units are inch pounds.
³ Units are lbs.

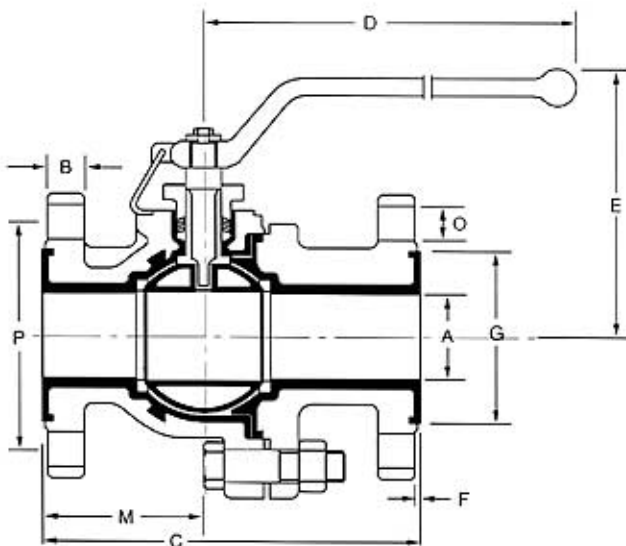

Materials Of Construction

Body, Ball, & Flange	PFA Lined Ductile Iron
Stem	PFA Lined Stainless Steel
Gland & Gland Stud	Stainless Steel
Body Stud	B7 Carbon Steel
Stem Packing & Seats	PTFE
Handle	Ductile Iron

Materials Of Construction

Part	911 & 944	911XP & 944XP Valves Only
Ball	PFA Lined Steel or Ductile Iron	PFA Lined Steel or Ductile Iron
Body & Tail	PFA Lined Ductile Iron*	PFA Lined Ductile Iron*
Stem	PFA Lined Stainless Steel (CD4MCu)	PFA Lined Stainless Steel (CD4MCu)
Follower	Stainless Steel (CD4MCu)	Stainless Steel (CD4MCu)
Follower Studs	ASTM A193 Grade B7 (Zinc Plated)	ASTM A193 Grade B7 (Zinc Plated)
Follower Nuts	ASTM A194 Grade 2H (Zinc Plated)	ASTM A194 Grade 2H (Zinc Plated)
Body Studs or Bolts	ASTM A193 Grade B7 (Zinc Plated)	ASTM A193 Grade B7 (Zinc Plated)
Body Stop Peg	Carbon Steel	Carbon Steel
Static Eliminator	302 Stainless Steel	Carbon Graphite Filled PTFE
Stem Packing & Seats	PTFE	PTFE
Hub Bolt & Washer	Carbon Steel	Carbon Steel
Handle	Ductile Iron	Ductile Iron
Spring Washers	17-7PH Stainless Steel	17-7PH Stainless Steel
Bonnet Extension	- - -	PFA Lined Carbon Steel
Stem Extension	- - -	17-4PH Stainless Steel
Bonnet Studs	- - -	ASTM A193 Grade B7
Bonnet Nuts	- - -	ASTM A194 Grade 2H
Stem Packing & Seats	- - -	PTFE
Lantern Ring	- - -	Carbon Graphite Filled PTFE

*FEP is available only for the 944 & 944XP.

Pressure-temperature ratings Per ANSI H16.42
(Maximum differential pressure at shut-off - for Tuffline 900 Series)

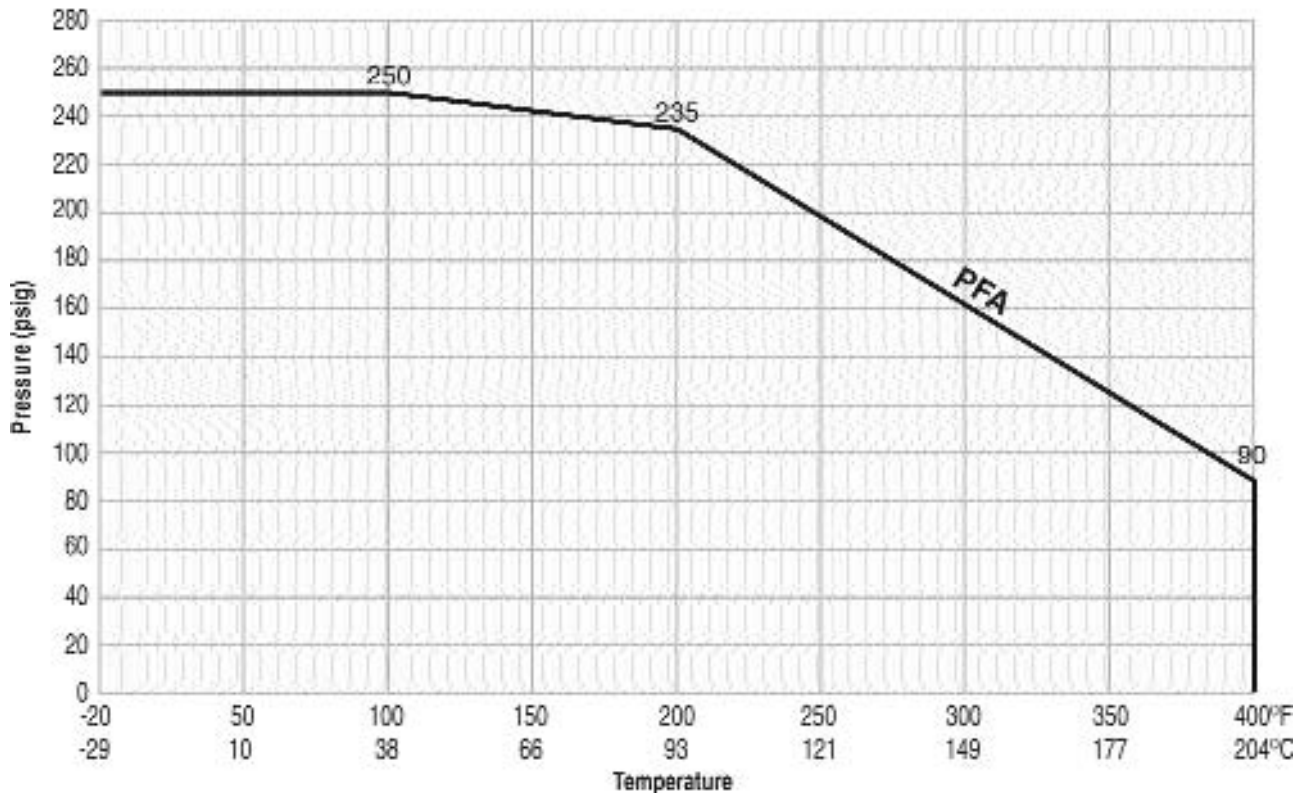

Lining Materials Data

In the manufacture of fully lined products the choice of lining materials and the method of lining are critical considerations, as all wetted parts are lined with a corrosion resistant material.

Tuflined ball valves are designed with cast dovetail recesses and machined grooves that lock the liner to the body casting. The fluorocarbon must therefore be molded in a liquid state. PFA was selected as lining materials because of its melt processibility, as well as PFA's many other desirable features.

PFA

Unpigmented PFA is the lining material used for all 900 Series & 090 Tuflined ball valves.

PFA is a class of fluoropolymers that offers the processing ease of conventional thermoplastics but substantially extends its temperature limits. It is a copolymer that combines the carbon-fluorine backbone of fluorocarbons with a perfluoroalkoxy side chain.

PFA has features that make it extremely desirable as a liner for corrosive fluid flow applications. In addition, PFA has been found to be better in handling some monomers, such as butadiene, permitting the use of PFA lined products on a wider range of applications.



PFA is chemically inert, heat resistant, weather resistant, stress cracking resistant, and has negligible moisture absorption. It has anti-stick characteristics and a low coefficient of friction which reduce torque. It is molded and machined to close tolerances for excellent sealing and wear resistance between parts.

PFA is a true thermoplastic and is melt processible, allowing it to be molded to extremely difficult shapes.

PFA resin has a branched polymer chain that provides good mechanical properties at melt viscosities much lower than those of PTFE. However, the unique branch in PFA is longer and more flexible, leading to improvements in high temperature properties, melting point, and thermal stability. The strength and stiffness of PFA at high operating temperatures are equivalent to or better than those of PTFE; and creep resistance is better than PTFE over a wide temperature range. PFA flex life is excellent.

Physical Properties

PFA (Perfluoroalkoxy)

Property	ASTM method	Value
Melting point	---	575 - 590°F
Tensile strength, 73°F	D638	3800 psi
Elongation, 73°F	D638	300%
Flexural modulus, 73°F	D790	100,000 psi
Impact strength, 73°F	D256	No break
Coefficient of linear thermal expansion per °F (70° to 212°F)	D646	6.7 x 10 ⁻⁵
Flammability	D635	Nonflammable
Weather and chemical resistance		Excellent

How to order.

Specify: Size, Figure Number, Materials, and Actuator.

Example:

2" 944/PFA, Wrench-Operated.

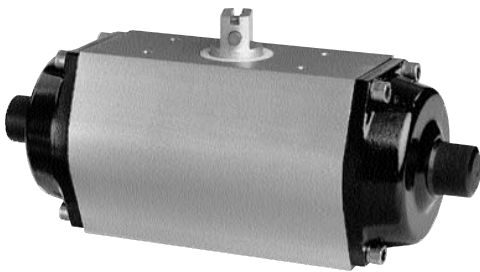

Automation.

Tufline fully lined ball valves can be supplied with a variety of manual, pneumatic, or electric actuators. Xomox also manufactures a complete line of control devices.

Actuation is easier because these are low torque, quarter-turn valves. Automation is simple and convenient because Xomox provides single-source responsibility for valves, actuators, and control accessories.

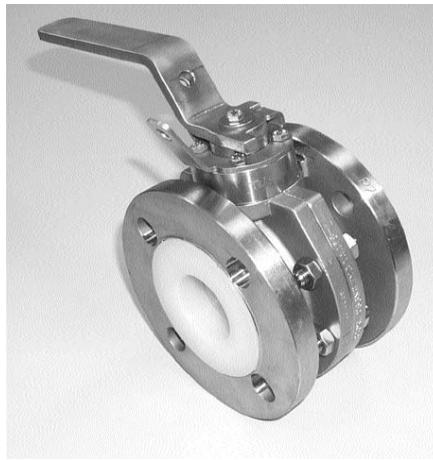

R40XL & K202.

(formerly 093 & 092)

These full-port lined ball valves are short-pattern valves. The R40XL is a tank-bottom valve. Contact your Xomox representative for more information on these products.

Custom designs and modifications.

The products featured in this catalog are available in other sizes and materials from Xomox Special Products Group. They provide design, engineering, and manufacturing services for custom products and modifications.

Oxygen and chlorine valves.

Valves designated for oxygen or chlorine service are thoroughly cleaned, tested, and dried per internal Xomox oxygen and chlorine standards. Flanges are sealed and valves are packaged in plastic containers.

Vacuum service.

Tufline fully lined ball valves are satisfactory for applications ranging from full industrial vacuum service up to 250 psi. All Tufline ball valves conform to the ANSI B16.42 specification for ductile iron flanges and fittings.



Locking devices.

Locking devices are available for Tufline valves in order to secure valves in either the open or closed position.

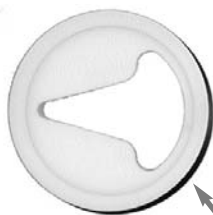

Lined ball valves characterized for control.

Tufline V-Port Lined Ball Valves have seats that are characterized to provide repeatable flow control.

Standard characterized seats provide an equal percentage characteristic. Other characteristics are available.

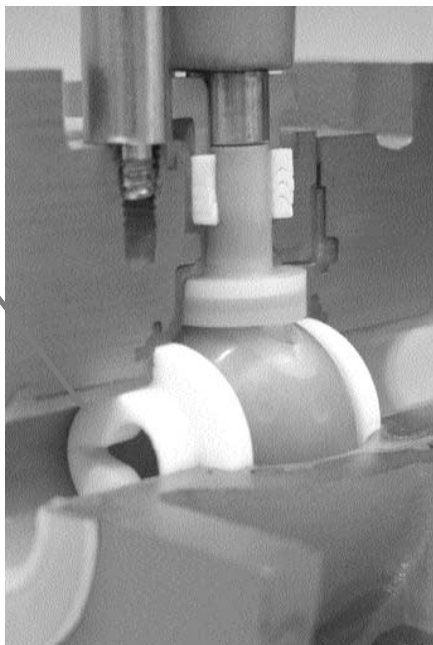

Both 911 full port and 944 standard port valves can be provided with this modification.

Valves are available for manual control or as a complete control valve package with pneumatic or electric actuation.

Global Capabilities For Global Customers

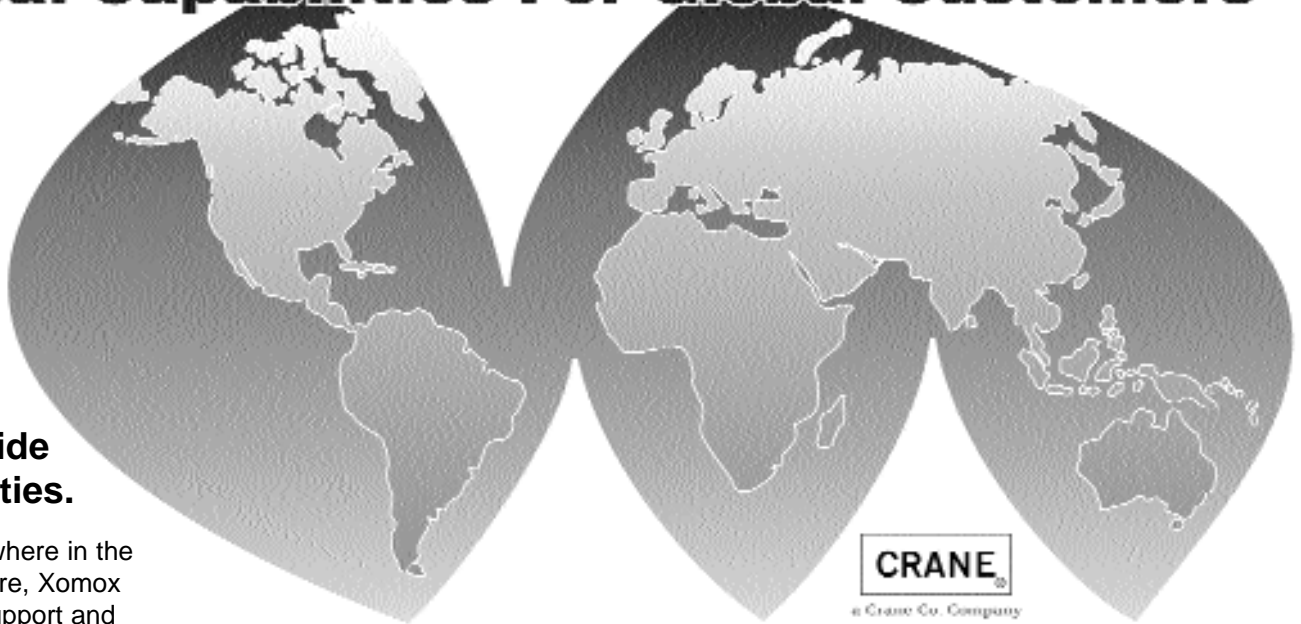

Worldwide capabilities.

No matter where in the world you are, Xomox technical support and services are available from:

- 16 Manufacturing Facilities
- 18 Service Centers
- 50 Sales Offices
- More than 200 Xomox Authorized Distributors

Product selection.

Xomox offers the broadest line of process valves, actuators, accessories, and related services including:

- Tuflin® Process Valves
- Saunders Diaphragm Valves
- Matryx® Rack & Pinion, Vane Actuators
- Xomox® XRP™ Actuators

Product responsibility.

Xomox's concern for product performance extends to the product's period of service. We feel it is important for users to also be aware of their responsibilities. Our products are manufactured and used in numerous applications with a wide variety of service conditions. While general guidelines are often furnished, it obviously is not possible to provide complete and specific performance data for every conceivable service condition.

Global locator.

For a listing of Xomox Manufacturing Facilities, Service Centers, Regional Offices, and Authorized Distributors, visit our web site www.xomox.com.

Xomox literature.

All Xomox catalogs and technical data are available as PDF files at www.xomox.com.

Phone support.

Call your nearest Xomox Sales Office or the Xomox World Headquarters:
Phone: 513-745-6000
Fax: 513-745-6093

Corporate strength.

Xomox is a Crane Co. company. Through the Crane Co. association, Xomox offers even greater global capabilities and breadth of product lines.

Xomox Corporation

World Headquarters
4444 Cooper Road
Cincinnati, Ohio 45242



Therefore, the end user must assume final responsibility for proper evaluation, application and performance of all products. The contents of this document are presented for information purposes only. Every effort has been made to ensure accuracy. This information is not intended to be construed as warranties or guarantees, expressed or implied, nor imply use applicability, for products or services described herein. We reserve the right to modify or

improve the designs and specifications of such products at any time without notice. As the manufacturer, Xomox sells its products and services pursuant to its standard terms and conditions of sale, including its limited warranty, copies of which are available upon request. Xomox limits its liability specifically to the replacement or repair of defective items, or to a refund for same. Xomox does not accept liability for any incidental or consequential damages.